

DESCRIPTION

The Door Mounted Safety Sensor (DMSS) (8310-804) detector is a door-mounted presence detection system that is used on automatic pedestrian swing doors. Unlike other door-mounted sensing devices, the sensors unique electronic architecture allows the detection modules to be mounted near the top of the door, out of harm's way. A rotating cam is used for the range adjustment of the detection zone. Width patterns may be altered by adding slave modules to the master module. These slave modules are simply added by inserting them into the aluminum extrusion, then connecting them with the attached flat ribbon cable to the next module without interrupting other modules in the same extrusion. Once installed, the detection zone (in addition to being adjustable for distance) can be angled independently from the other modules.

Each DMSS module consists of two optics, a transmitter (TX) and a receiver (RX), and functions independently of the other modules. The transmitter emits an extremely precise beam, which measures approximately 4" in diameter at a distance of 8'. The receiver, in turn, receives the infrared beam reflected off of the floor. This transmission and reception forms a detection triangle, which is the basic premise of detection (called triangulation). Should this angle be interrupted, detection will occur. Detection is NOT based upon the intensity of the beam, and in principle will not be affected by the color or background of the object that interrupts the angle.

TECHNICAL SPECIFICATIONS

DESCRIPTION	SPECIFICATION
Power Supply	12 to 24 VAC \pm 10% / 12 to 24 VDC \pm 10%
Current Consumption:	Master: On = 60 mA max. / Master: Off = 30 mA max. Slave: On = 40 mA. Max. / Slave: Off = 30 mA max.
Input Inhibit	12 to 24 VAC \pm 10%: / 12 to 24 VDC \pm 10% / Inhibited when voltage is applied
SMR Input Data	12-18 VDC: Inhibited when voltage is applied
Output Interface; relay	Relay; max. contact rating is 1A @ 30v (resistive)
Detection Range	0' to 8'
Distance Adjustment	2' to 8' / Rotating cam with linear adjustment
Max. Mounting Height	8'
Detection Time	< 50 ms
Detection Signal Duration	Infinite Presence Detection
Output Hold Time	Potentiometer Range: 0.1 to 4.5 seconds.
LED Indications	Master: Red LED = Detection Green LED = Active Output Slave: Red LED = Detection
Operating Temperature Range	-30° F to 140° F
PCB Dimensions	Master: 10.91" x 1.5" Slave: 8.75" x 1.5"
Connection to Door Controller	8 Position Screw Terminal on Master PCB
Connection: Master to Slave	Flat Ribbon Cable With Connectors and Key Lock
Max. Number of Slaves	Standard = 9 / With Monitoring = 8 max.
Functions Selection	Detection Mode - NO or NC Normal Mode or Background Analysis Mode

COMPONENT ID

DOOR MOUNTED SAFETY SENSOR



DMSS Quick Disconnect Cable (8310-847)



Jamb Cap (2)

INSTALLATION TIPS



- The sensor must be firmly fastened to prevent vibration.

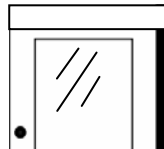

- Sensor must be in a location that does not interfere with door hardware (finger guards, lock rods, etc.).

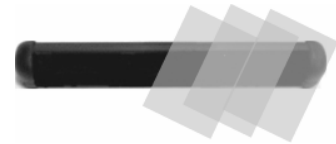

- The sensor must not have any unwanted objects likely to move or vibrate in its path.

**SAFETY
PRECAUTIONS**



- Shut off all power going to the header before attempting any wiring procedures.
- Maintain a clean & safe environment when working in public areas.
- Constantly be aware of pedestrian traffic around the door area.
- Always stop pedestrian traffic through the doorway when performing tests that may result in unexpected reactions by the door.
- Always check placement of all wiring and components before powering up to ensure that moving door parts will not catch any wires and cause damage to equipment.
- Ensure compliance with all applicable safety standards (i.e. ANSI A156.10 / 19) upon completion of installation.

**MECHANICAL
INSTALLATION-
PREPARING AND
MOUNTING THE
SENSOR**

1. Install push or pull arm.
2. Remove the screw that secures the end cap to the Door Mounted Safety Sensor extrusion (as shown in Picture 1 below).



3. Remove the plastic lens by pulling the lens out from the top of the extrusion (as shown in Picture 2 above). Do not use a screwdriver to pry the lens, as cracking may occur.



CAUTION: REMOVE THE MASTER AND ALL SLAVE CIRCUIT BOARDS FROM THE ALUMINUM EXTRUSION BEFORE PERFORMING ANY DRILLING. WHEN COMPLETE, ENSURE THAT ALL METAL SHAVINGS ARE CLEANED FROM THE EXTRUSION BEFORE RE-INSERTING THE CIRCUIT BOARDS.

4. Picture #3 below shows the angle adjustment clip in its proper position within the extrusion (PCB's are removed, and clip is shown at end of extrusion for clarity only). To remove the clip, simply pull the tab out away and downward from the extrusion, then rotate the module out from extrusion as shown in picture #4. To re-install, simply reverse the procedure - the PCB must first be installed into the adjustment clip, then installed into the aluminum extrusion.

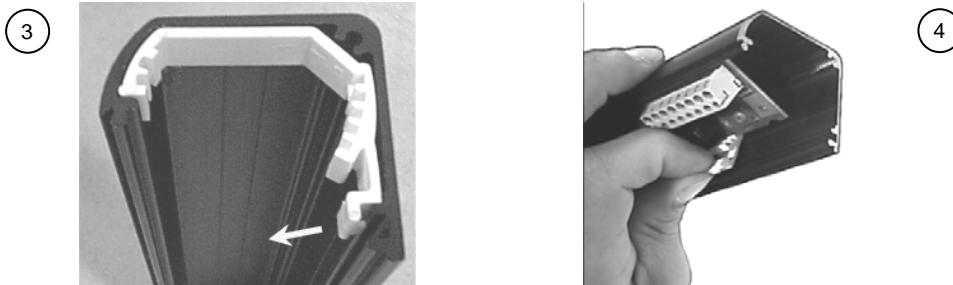

IMPORTANT NOTE: The end of the extrusion that is towards the pivot end of a center hung door, should be in far enough from the edge of the door, as shown in picture #5, to prevent the end cap of the DMSS from rubbing against the finger guard during door movement. Pay particular attention on the safety side of the door. Hinge hung doors will not require as much clearance between the end of the DMSS and hinge-side jamb as shown in picture #6 below. At the leading edge of the door the edge of the DMSS, including the end cap, should be as close as possible to the leading edge of the door without creating mechanical interference with the door jamb or with an adjacent door (pairs).



NOTE: If a brick store front is encountered during installation, route the sensor wiring through the door header.

5. Hold the Door Mounted Safety Sensor extrusion up to the top of the door. Insure that the extrusion is oriented correctly as shown below.

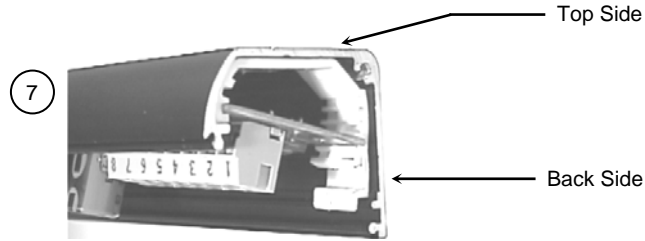

6. Mark and drill the extrusion (as shown in pictures 8, 9 and 10 below) where the mounting holes (one at each end) should be located. Also, be sure to mark and drill the proper end for an additional hole to be used for wire passage. Wire passage hole should be approximately 1/4" diameter. Screw mount holes only serve as a pilot hole for ease of installing the self-drilling screws that are provided.

NOTE: Take care to avoid screw holes near the seams of the door, where it may be difficult to drill and install a screw, and possibly damage the inside structural braces of the door.

7. Hold the DMSS back up to the door at the pre-drilled location and attach the unit to the door with the 2 screws provided (as shown in picture 11 below). Insure the DMSS extrusion is tight against the door.

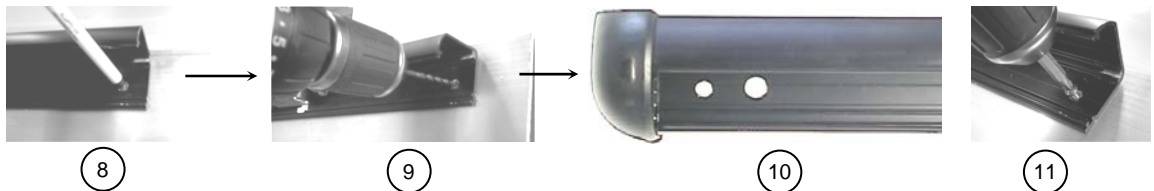

8. If Door Mounted Safety Sensors are to be mounted on both sides of the door, a wire passage hole will be required through the door to go from the approach side to the safety side, as shown below. Again, be sure not to drill through any through-bolts or braces within the door. A cutaway view below (Picture 13) shows wire passage through the door. Picture 12 and 14 shows an approximate location for the wire passage hole. The extension wire going between the terminal blocks should be approximately 18" long and can then be cut back if needed. Refer to the detailed drawing below for wire routing, connector and cable location.

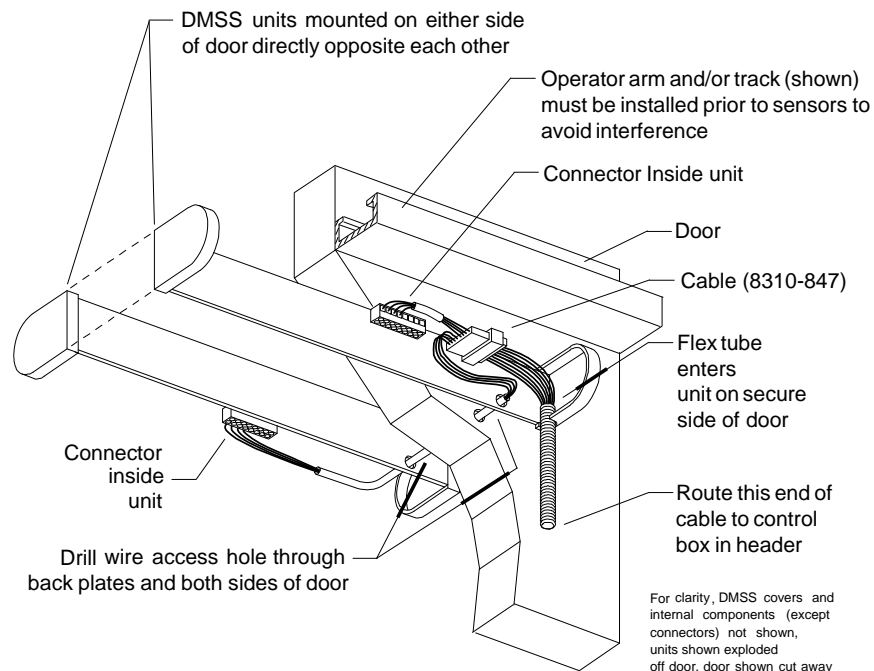
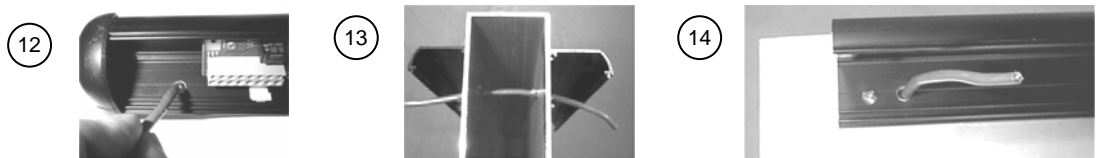

**MECHANICAL
INSTALLATION-
PREPARING AND
MOUNTING THE
SENSOR (Cont'd)**

9. Next, a wire passage hole will be required in the door header (Picture 15) and also in the jamb tube (Picture 16) at approximately the same height as the Door Mounted Safety Sensor. The wire transfer hole in the jamb should be at the secure side of the door. Normally this would be the interior side. Feed the wire through the jamb tube up to the header. Insure that enough wire is left out to reach the Door Mounted Safety Sensor terminal block.

15



16



NOTE: Ensure there is enough slack in cabling to allow adequate movement of the cable throughout the range of door travel.

10. Once all cabling is in place, the plastic sheath must be installed over the wire coming out of the jamb tube. This must be done before making final connection to the terminal block. The sheath may have to be cut to fit the application. Once the wire is fed though, the plastic cap may be installed on the jamb, over the transfer hole.

17



18



19



← Plastic ribbed sheath

**ELECTRICAL
INSTALLATION-
CABLING &
CONNECTIONS**

1. With cabling in place, wiring at the terminal connector on the DMSS master module (picture 20) may be completed. Wiring will vary according to the application. Available positions on the connector are shown below:

20

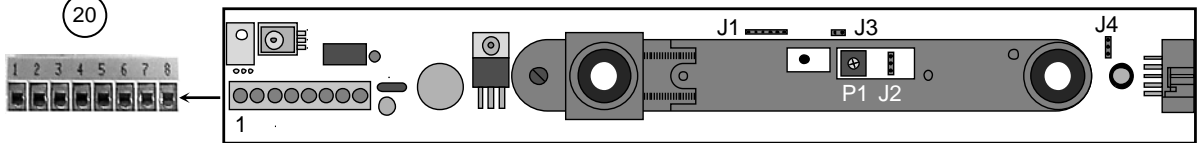

TERMINAL	EXPLANATION OF WIRING CONNECTIONS
1 TST	TEST DATA - Used with SMR systems only.
2 GND	GROUND - Negative terminal if Input inhibition is used.
3 INH	INPUT INHIBITION - All detection is ignored. Infrared emission is stopped. Inhibition occurs when 12 to 24 VAC ± 10% or 12 to 24 VDC ± 10% is applied between terminal 3 and terminal 2.
4 NO	In the relay mode, depending on the position of JP2 this terminal will provide either a NO or NC contact. (JP2 factory default will result in NC on terminal 4)
5 NC	In the relay mode, depending on the position of JP2, this terminal will provide either a NO or NC contact. (JP2 factory default will result in NO on terminal 5)
6 COM	COMMON - Contact for relay.
7 -	NEG. POWER - This terminal is used for power input. A voltage of 12 to 24 VAC ± 10% or 12 to 24 VDC ± 10% must be supplied.
8 +	POS. POWER - This terminal is used for power input. A voltage of 12 to 24 VAC ± 10% or 12 to 24 VDC ± 10% must be supplied.

**ELECTRICAL
INSTALLATION-
CABLING &
CONNECTIONS
(Cont'd)**

- Once all wiring has been completed, the end caps and lens may be installed. At the DMSS end of the cable (picture 23), leave enough slack to allow a relaxed connection at the terminal block. Locate the DMSS end cap that goes towards the hinged end of the door. Remove the tab at the bottom of the cap (picture 21) to allow insertion of the plastic sheath. Insert the plastic sheath (picture 22) and install the end cap. The DMSS lens may then be installed to fit tight against the end cap and plastic sheath to hold it in place, as shown in picture 24. Leave the end cap off at the opposite end until all mechanical adjustments have been completed.

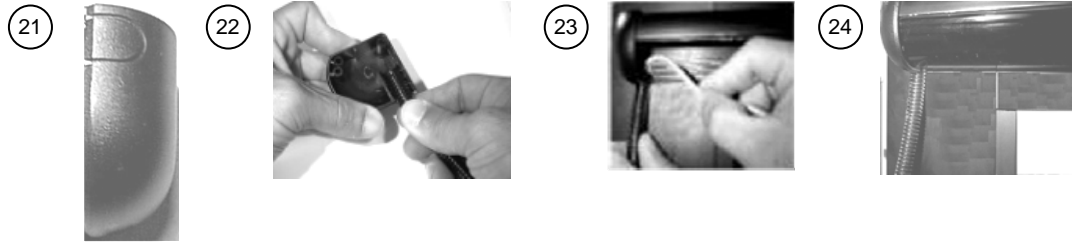

* REFER TO THE BACK OF THIS GUIDE FOR WIRING SCHEMATICS.

**MECHANICAL
ADJUSTMENTS –
POSITIONING AND
ANGLING THE
MODULES**

- The positioning of the modules within the aluminum extrusion will be as shown below. The modules will always be positioned so that the transmitter (TX) is at the leading edge of the door. Modules may be flipped around to accommodate handing of doors.

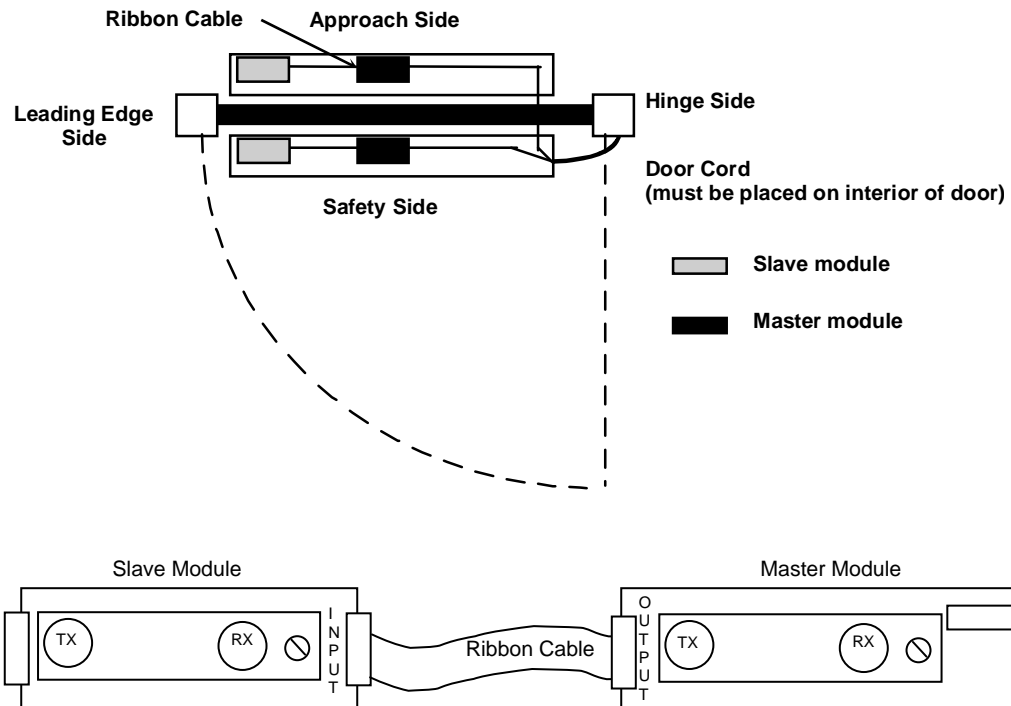

MECHANICAL ADJUSTMENTS – POSITIONING AND ANGLING THE MODULES (Cont'd)

2. The angle of each module may be set independently. Use the charts below to help determine the angling. The angles may have to be altered once the units have been powered up and walk-tested.

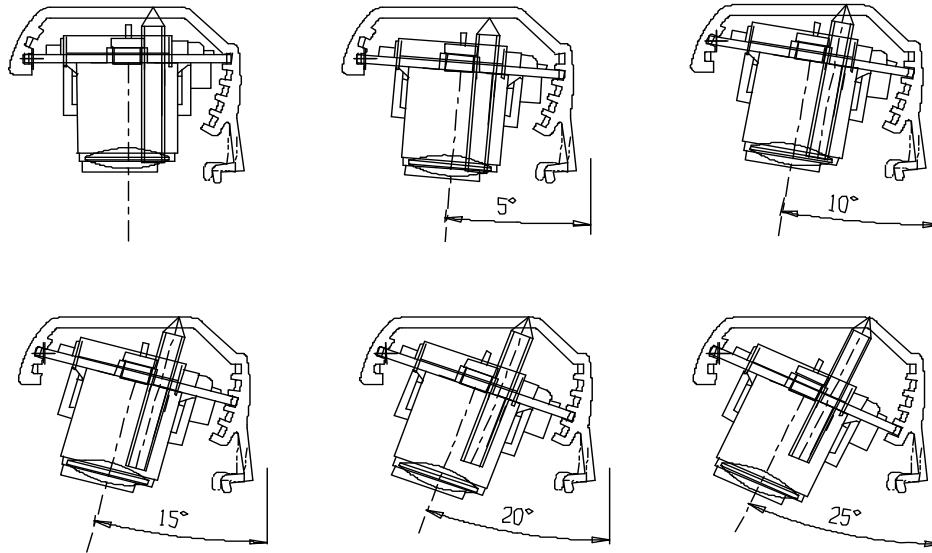

POWER-ON POSITIONING, ANGLING AND ADJUSTING THE MODULES

DEAD ZONE DISTANCE FROM FLOOR (B)	DOOR MOUNTED SAFETY SENSOR ANGLE (C)					
	0°	5°	10°	15°	20°	25°
8"	0	6"	12 ½"	19 ¼"	26"	33 ¼"
12"	0	6"	12"	18"	24 ½"	31 ½"
16"	0	5 ½"	11 ¼"	16 ¾"	23 ¼"	29 ½"
20"	0	5 ¼"	10 ½"	16"	21 ½"	27 ½"

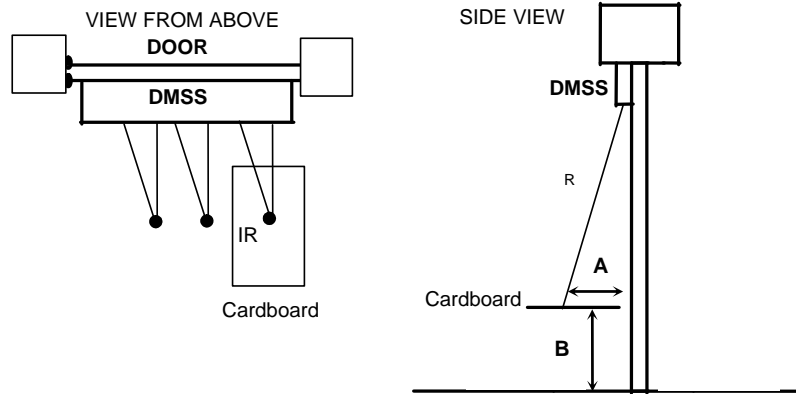

3. The following procedures will be used to adjust each module's detection zone upon power-on, and must be made with the Background Analysis jumper set to 'Normal Mode'.
- Power the sensors up with 12 to 24 VAC ± 10% or 12 to 24 VDC ± 10%. LED status should reflect what was configured for the relay output.
 - Use a white, gray, or black piece of cardboard about 8" x 11" and hold it as shown in the diagram above.
 - Move the cardboard from the floor upward until it is detected. This will determine the height of the dead zone (B distance).
 - Measure the height at which the cardboard was detected.
 - If this height does not fall between 12" & 16" above the floor or does not meet your requirements, an adjustment must be made to the detection distance.

POWER-ON POSITIONING, ANGLING AND ADJSUTING THE MODULES (Cont'd).

33

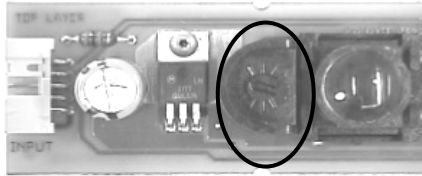

Detection Distance Adjustment

- One notch of the distance adjustment corresponds to approximately 4".
- If Zone B is too high: Turn the distance adjustment clockwise to increase the detection distance and to decrease Zone B.
- If Zone B is too low, turn the distance adjustment counter-clockwise to decrease the detection distance.
- Per current ANSI A156.10, the detection zone must be within 28" of the floor. Ideally, each detector should be adjusted so that detection occurs at 12" to 16" above the floor. Less than 12" of Zone B may result in occasional false triggering of the sensor.
- Once all sensors have been adjusted, activate the door several times and allow it to go through a full cycle each time. Insure that no false triggering is occurring, as would be indicated by the door recycling or stopping by itself at any point of travel.
- Ensure compliance of all applicable safety standards (i.e. ANSI A156.10 / 19).
- Install all remaining covers, end caps, screws, etc.

TROUBLE-SHOOTING

PROBLEM	POSSIBLE CAUSE	CORRECTIVE ACTION
Door Mounted Safety Sensor does not work at all. No LED indications.	Faulty power supply Faulty connections	Power supply must be 12 to 24 VAC \pm 10% or 12 to 24 VDC \pm 10%. Check for this power at terminals 7 & 8 of the affected DMSS module.
DMSS output appears to be working opposite of what is expected.	Relay output may be configured improperly.	Refer to Appendix for relay configurations. Be sure to observe the LED indications on the affected modules to help determine status.
Door stops by itself before reaching the full open position.	Safety side DMSS may be seeing an adjacent wall or rail behind the door near the open position.	Observe the LED status on safety side of door. Find the Door Mounted Safety Sensor module that is falsely being triggered. Check for: <ul style="list-style-type: none"> <input type="checkbox"/> Proper detection angle <input type="checkbox"/> Detection range adjustment Door Mounted Safety Sensor may need to be in h bited at a specific point of door travel at the safety side for proper operation. Refer to the terminal connections on page 4.
Activation or safety is being held triggered.	DMSS detection module may be seeing the floor or unwanted object near door.	Reduce the detection range on the affected module(s). Detection should occur at 12" to 16" above the floor.
Erratic detection behavior is occurring throughout the door's opening and closing cycle.	Possible faulty wiring at door transfer location.	Check each wire for continuity with as multi-meter, at the transfer location. Move the wires around during testing to help locate any breaks. Replace faulty wiring as necessary.

COMPANY CONTACT

Do not leave problems unresolved. If a satisfactory cannot be achieved after troubleshooting a problem, please contact LCN at 1-800-526-2400. If you must wait for the following workday to call, leave the door inoperable until satisfactory repairs can be made. Never sacrifice the safe operation of the automatic door or gate for an incomplete solution.

For more information, visit www.lcn.ingersollrand.com.

8310-804 DOOR MOUNT
SAFETY SENSOR
SINGLE DOOR WIRING

