





Hi/Shear® Magnetic Door Locks

SDC Hi/Shear® magnetic lock utilizes several of the most innovative and unique design attributes. The Hi/Shear is the magnetic lock that gives those who want a better shear lock all the latest features.

The SDC Hi/Shear® is a totally concealed, high security, failsafe locking mechanism with superior appearance. The patented Hi/Shear® electromagnetic lock design incorporates a “floating” armature assembly and special alloy steel locking “tabs” on both the lock and armature assemblies, that may be adjusted both vertically and laterally to compensate for wide door gaps and warped or misaligned doors.

Hi/Shear® magnetic locks are ideal for use on commercial grade hollow metal and wood doors and metal frames and Herculite doors with top rails.



Concealed



Semi-Concealed



Surface Mount

Hi/Shear® Magnetic Lock Features

Door Static and Alignment Sensor

The door static sensor ensures that the door is at rest and aligned, before the magnet is permitted to energize, eliminating potential for lock misalignment.

Lateral Alignment Adjustment

Lateral adjustment of shear tabs to compensate for warped or misaligned doors, permitting accurate locking.



Adjustable Tabs

Vertical Alignment Adjustment

Vertical adjustment of the armature compensates for wide door gaps.

“Floating” Assembly

A unique “floating” action makes for easier armature lift when the magnet is energized and provides the ability to overcome wide door gaps.

2000 or 2700 Lbs Holding Force

2000 or 2700lbs. of holding force without current inrush or high operating temperature normally associated with shear locks.

Alloy Steel Shear “Tabs” on Lock and Armature

Alloy shear tabs are used on both the lock and the armature to ensure continued high holding force. There is no profiling of the soft armature steel that may be prone to wear and reduced holding force.

Advanced Electronic Circuitry

Advanced electronic circuitry that incorporates door static, positioning and timed relock sensor and automatic voltage sensing for 12/24VDC input.

Quieter Operation

Noise dampeners greatly reduce the noise associated with locking and unlocking of other shear locks on the market.



UL10C Positive Pressure Compliant
UBC Classified in accordance with Uniform Building Code standard 7-2 “Fire Test for Door Assemblies”



Concealed Hi/Shear®

2000 Lbs Holding Force, 8" x 1-1/2" Lock

- 1561** Integrated electronics, 1 5/8" depth for 1 3/4" to 2" frames
1562 External electronics, 1 1/4" depth for 1 1/4" to 1 1/2" frames

2700 Lbs Holding Force, 10-7/16" x 1-1/2" Lock

- 1565** Integrated electronics, 1 5/8" depth for 1 3/4" to 2" frames
1566 External electronics, 1 1/4" depth for 1 1/4" to 1 1/2" frames

Specify Armature

Armature supplied with lock. Specify type required:

- 1565/1566 ITC, FTC or HTC
 1561/1562 ITCM, FTCM or HTCM

- ITC** Standard mounting armature kit for aluminum and hollow metal doors with 3/8" to 1 1/8" deep top channels, wood doors and factory prepared hollow metal flush edge doors.
ITCM Mounting kit for field prepared horizontal mounting in hollow metal doors with flush edge.
FTC Mounting kit for field prepared horizontal mounting in hollow metal doors with flush edge.
FTCM Mounting kit for field prepared horizontal mounting in hollow metal doors with flush edge.
HTC Mounting kit for 1-15/16" deep Herculite channels
HTCM Mounting kit for 1-15/16" deep Herculite channels

Options

- BA** Bond sensor indicates proper armature contact or reduced holding power due to improper armature contact or tampering. SPDT 0.25Amp (not available on 1562/1566)
DPS Door position switch indicates door open or closed. SPDT 0.25 Amp maximum.
HTR Herculite top rail armature adjustment bracket for leading edge adjustments for 1565 and 1566
HTRM Herculite top rail armature adjustment bracket for leading edge adjustments for 1561 and 1562
WDRB Wood door reinforcement box for 1565 and 1566
WDRBM Wood door reinforcement box for 1561 and 1562



Specifications

Automatic Voltage Sensing Input

- 1561/1562** 650/350mA @ 12/24VDC
1565/1566 800/400mA @ 12/24VDC

Lock Body Dimensions

- 1561** 8"L x 1-1/2"W x 1-5/8"D (203.2 x 38.1 x 41.3mm)
1562 8"L x 1-1/2"W x 1-1/4"D (203.2 x 38.1 x 31.7mm)
1565 10-7/16"L x 1-1/2"W x 1-5/8"D (265.1 x 38.1 x 41.3mm)
1566 10-7/16"L x 1-1/2"W x 1-1/4"D (265.1 x 38.1 x 31.7mm)

Armature Assembly Dimensions

- 1561/1562** 8"L x 1-1/2"W x 7/8"D (203.2 x 38.1 x 22.2mm)
1565/1566 11"L x 1-1/2"W x 7/8"D (279.4 x 38.1 x 22.2mm)

Hi/Shear® Innovative Design

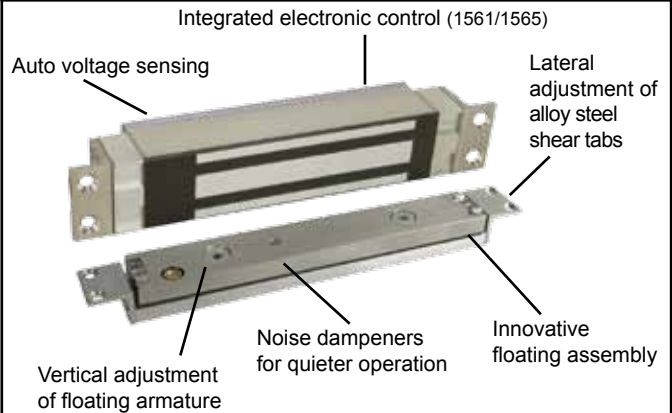

Hi/Shear® with integrated electronics for standard 1 3/4" - 2" frames

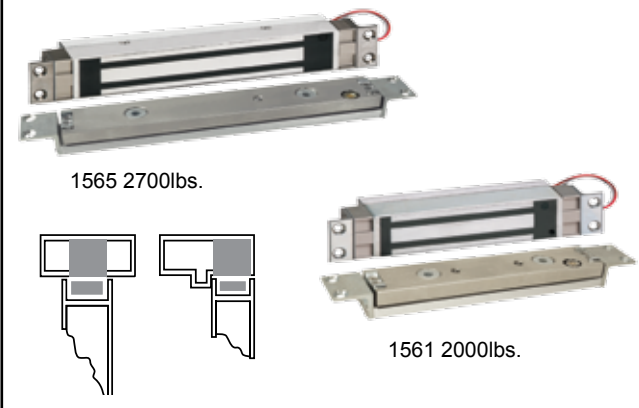

Hi/Shear® with external electronics for narrow 1 1/4" - 1 1/2" frames

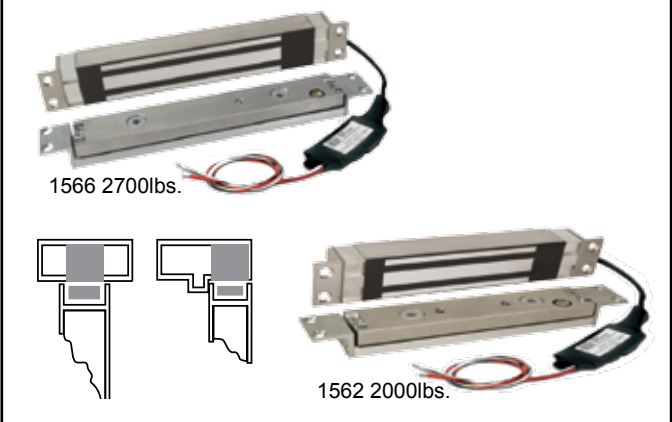

Protected by one or more of the following patents:
 4,826,223 4,986,581 5,000,497 5,006,723 5,003,779

Surface Mount Hi/Shear®

Surface mount configurations incorporate the innovative 2000 lb holding force Hi/Shear® electromagnetic lock in a compact housing smaller than many mini surface mount direct pull magnetic locks. The surface mount design also provides the advantage of mounting the Hi/Shear® on the secure side of the door opening, eliminating potential for tampering.

- 1561S** Surface mounted to the push side of an out-swing door. For metal door and frame, glass door with top rail and metal frame, or wood door and frame
- 1561TJ** Surface mounted to the pull side of an in-swing door. For metal door and frame, glass door with top rail and metal frame, or wood door and frame. This mounting configuration eliminates the need for cumbersome and unsightly top jamb Z brackets normally associated with pull side mounted of magnetic locks

1561S Surface Mount



Semi-Concealed Hi/Shear®

The semi-concealed configuration incorporates the innovative 2000 lb Hi/Shear® concealed electromagnetic lock with a surface mounted armature assembly. The semi-concealed design also provides the advantage of mounting the Hi/Shear® on the secure side of the door opening, eliminating potential for tampering.

- 1562SC** Semi-concealed mounted to the push side of an out-swing door. The mortise magnet is concealed in the frame and the armature is surface mounted on the door. For metal door and frame, glass door with top rail and metal frame, or wood door and metal frame.
- 1562SCHDB 1/2** Semi-concealed mounted to the push side of an out-swing glass door. The mortise magnet is concealed in the frame and the armature is surface mounted on the 1/2" glass door where no top rail is present utilizing the Herculite door bracket.
- 1562SCHDB 3/4** Semi-concealed mounted to the push side of an out-swing glass door. The mortise magnet is concealed in the frame and the armature is surface mounted on the 3/4" glass door where no top rail is present utilizing the Herculite door bracket.

1561TJ Top Jamb Mount



1562SC Semi-Concealed



Options

- BA** Bond sensor indicates proper armature contact or reduced holding power due to improper armature contact or tampering. SPDT 0.25Amp (not available on 1562 / 1566)
- DPS** Door position switch indicates door open or closed. SPDT 0.25 Amp maximum.

Specifications

Automatic Voltage Sensing Input

1561/1562 650/350mA @ 12/24VDC

Lock Body Dimensions

Mortise 8"L x 1-1/2"W x 1-1/4"D (203.2 x 38.1 x 31.7mm)

Surface 8"L x 1-3/4"W x 1-3/4"D (203.2 x 44.4 x 44.4mm)

Armature Assembly Dimensions

Surface 8"L x 1-3/4"W x 1"D (203.2 x 44.4 x 25.4mm)

Finish 628 Anodized Aluminum

1562SCHDB Semi-Concealed Glass Mount

