



**AMERICAN SPECIALTIES, INC.**  
 441 Saw Mill River Road, Yonkers, NY 10701  
 (914) 476.9000 • (914) 476.0688  
 www.americanspecialties.com

**MODEL №:**

**0663**

**ISSUED:**

**29 JAN 2019**

**REVISED:**

**24 JAN 2020**

**VELARE™ BTM (Pg 1 of 3)**

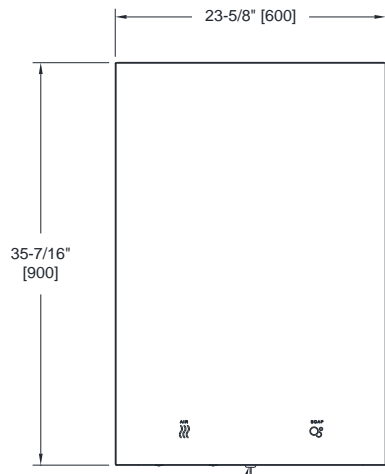

ASI TUMBLER LOCK  
KEYED E-114  
**FRONT VIEW**

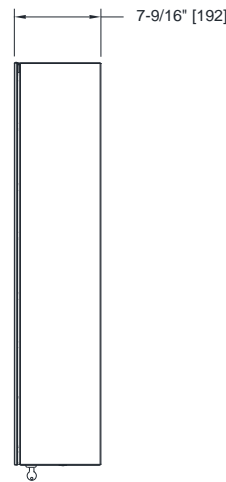

**SIDE VIEW**

**NOTE:**  
 ALL DIM'S INCH [MM]  
 ILLUSTRATION FOR REF ONLY AND NTS  
 FOR CLEANING INSTRUCTIONS SEE APPROPRIATE  
 SECTIONS IN PRODUCT CARE & MAINTENANCE  
 BULLETIN (PCM) ON ASI WEBSITE

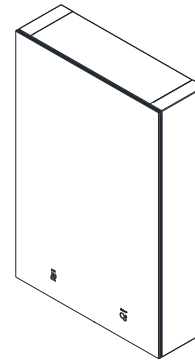

**ISOMETRIC VIEW (-1, -2)**

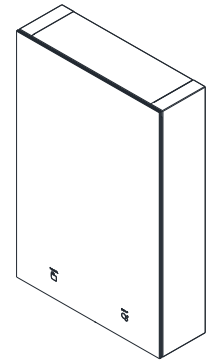

**ISOMETRIC VIEW (-T)**

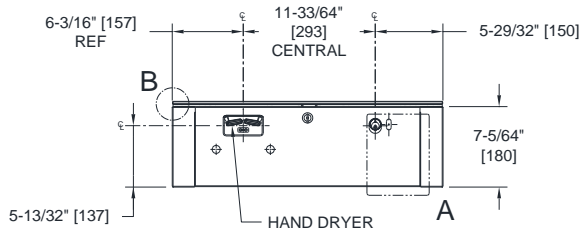

**BOTTOM VIEW (-1, -2)**

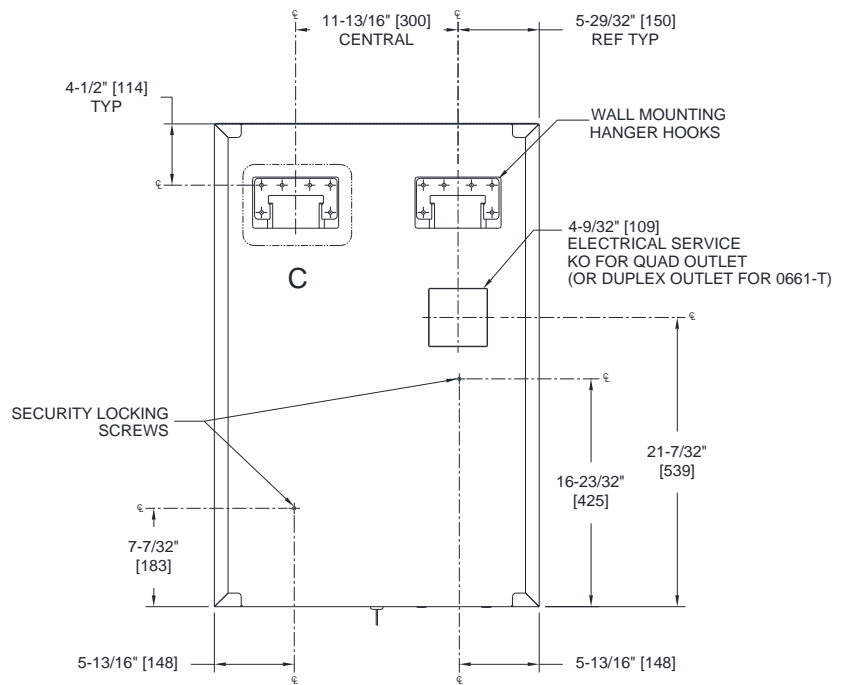

**BACK VIEW**

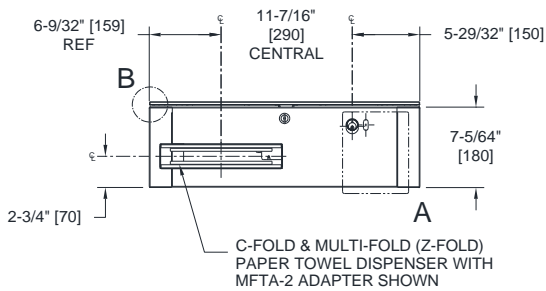

**BOTTOM VIEW (-T)**

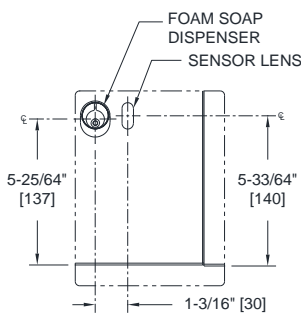

**DETAIL A**

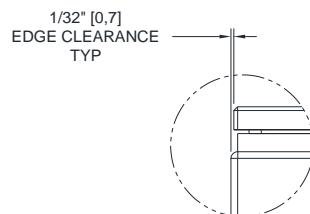

**DETAIL B**

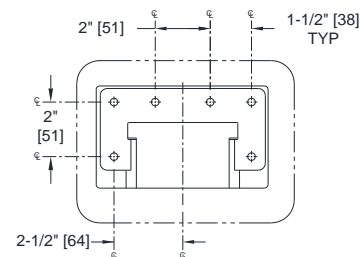

**DETAIL C**



**AMERICAN SPECIALTIES, INC.**  
441 Saw Mill River Road, Yonkers, NY 10701  
(914) 476.9000 • (914) 476.0688  
www.americanspecialties.com

**MODEL №:** 0663

**ISSUED:** 29 JAN 2019

**REVISED:** 24 JAN 2020

## VELARE™ BTM (Pg 2 of 3)

### SPECIFICATION

Velare™ BTM system cabinet has Tumbler Lock and Key Locking compartment prevents unauthorized access and removal. Full width 3/16" diameter [Ø4,8] concealed piano hinge for mirror door is hung with SS rivets. Mirror door is 1/4" [6] thick frameless tempered glass conforming to ASTM C-1048 with pencil edges and eased corners with SS sheet intermediate stiffener and SS back plate with integral welded support mounts, hinge and lock keeper. Mirror door has backlit legends and icons powered by AC Adapters to indicate functions provided from bottom panel of module per model definition:

- 0663-1 has "AIR" and "SOAP" legends - icons: Hands-Free Foam Soap Dispenser & 110-120V Automatic Dryer Model № 0196-1 with HEPA filter
- 0663-2 has "AIR" and "SOAP" legends - icons: Hands-Free Foam Soap Dispenser & 208-240V Automatic Dryer Model № 0196-2 with HEPA filter
- 0663-T has "TOWEL" and "SOAP" legends - icons: Hands-Free Foam Soap Dispenser & Towel Dispenser for C-Fold and Multi-Fold (Z-Fold) towels (with MFTA-2 included)

Support for mirror door is provided by twin damped gas springs to assist opening from 15° to 90° with soft-stop cushion at full open and when lowering to full closed position for locking. A welded on D-ring is provided inside door to allow attachment of a grip strap (optional, by others, see open views page 3). This can assist service individuals with height challenged reach range to pull down door after refilling or other service inside cabinet. Cabinet is 14, 16, 18, 20 and 22 ga 304 SS with Satin Finish on all exposed surfaces and has no exposed construction tabs or flaps, welding or fasteners. Adapter included (p/n MFTA-2) converts C-fold operation to accommodate Z-fold or Multi-Fold towels. Paper towels up to capacity limit of 500 towels are front loaded into chute when mirror door is open and require no additional key for access. HEPA filter requires periodic replacement when mirror door is open and requires key provided with dryer unit for access. Soap dispenser draws from 6L tank to provide approximately 17,650 uses between required periodic access for tank refill when mirror door is open and requires no additional key for access. Modules operate on 100 – 240 VAC provided to quad outlet (double-duplex) {or duplex outlet for 0663-T} (by others) concealed behind cabinet into which standard appliance power cord and AC adapters are plugged at installation. Matching filler modules (FM) are available for additional faucet spacing. Installation Guide and Dryer Owner Manual are provided with unit.

**Velare™ BTM Surface Mounted Mirror Door Cabinet with Foam Soap Dispenser and Hand Dryer or Paper Towel Dispenser shall be Model № 0663-\_\_\_\_\_ (-1 or -2 or -T) as manufactured by American Specialties, Inc., 441 Saw Mill River Road, Yonkers, New York 10701-4913**

### INSTALLATION

Mount unit on wall using twelve (12) № 12 self threading, pan-head screws (by others) through two (2) concealed mounting plates into appropriate anchoring and wall reinforcements and hang unit on hooks on mounting plates. Install two (2) № 12 self-threading locking screws (by others) into appropriate anchoring to prevent unit from being lifted off hanger hooks. Suggested mounting height is to position bottom of module 16" [406] to 20" [508] above vanity top. See complete guide before starting installation.

### OPERATION

Towels are self-feeding until supply is depleted from manually loaded stack. Use MFTA-2 with Z-Fold (Multi-Fold) towels, placed in towel chute with rounded lips down. Remove MFTA-2 when using C-Fold towels and store inside cabinet next to towel chute. HEPA filter is changed on cycle determined by maintenance needs for models with hand dryer. Foam type soap with a pH in range  $7 \pm 1.5$  and viscosity range 0~100 cP (mPa•s) is refilled into 6L tank on cycles determined by maintenance needs. Towel stack is replenished on cycle determined by maintenance needs. Locked compartment prevents unauthorized access or removal. See Owner Manuals for complete details of operation.



**AMERICAN SPECIALTIES, INC.**  
 441 Saw Mill River Road, Yonkers, NY 10701  
 (914) 476.9000 • (914) 476.0688  
 www.americanspecialties.com

**MODEL №:** 0663

**ISSUED:** 29 JAN 2019

**REVISED:** 24 JAN 2020

**VELARE™ BTM (Pg 3 of 3)**

**WIRING & TUBING CONNECTIONS NOT SHOWN FOR ENHANCED CLARITY**

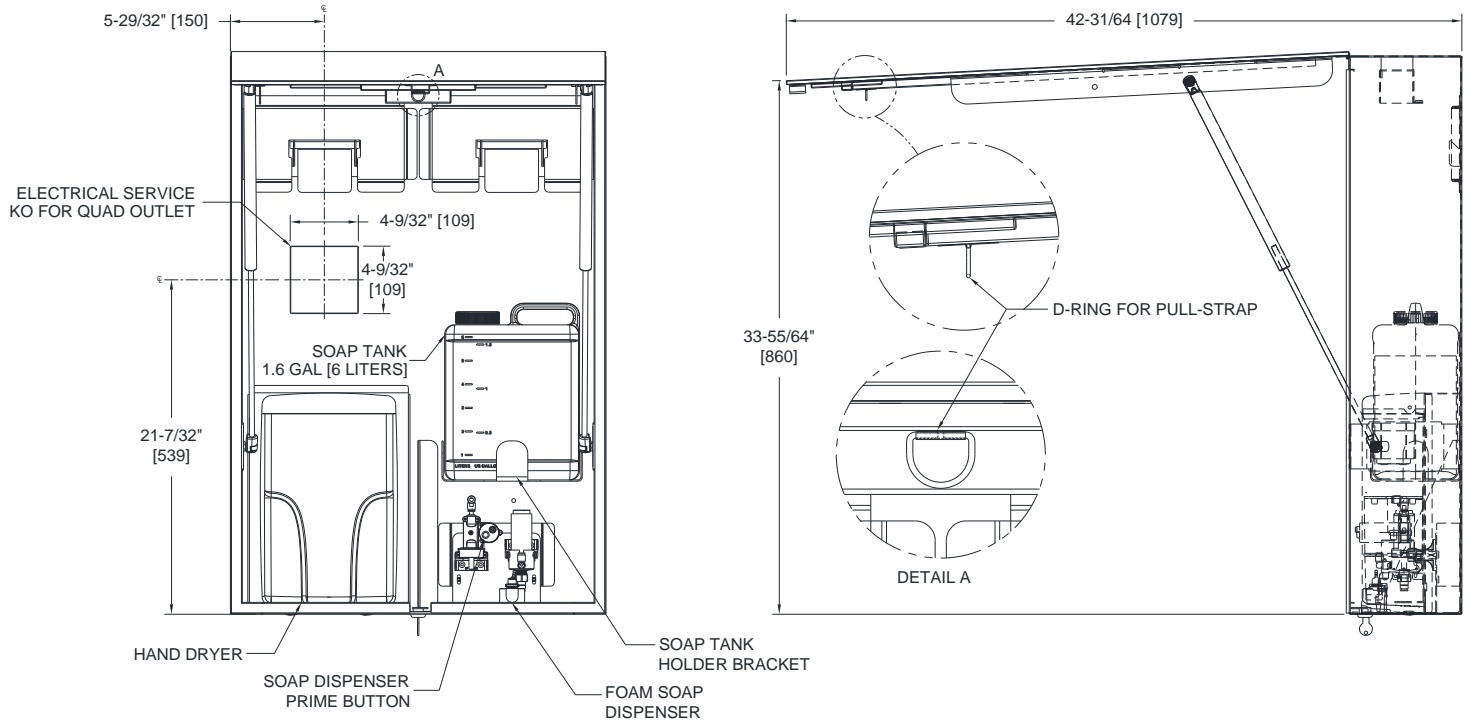

OPEN VIEW (-1, -2)

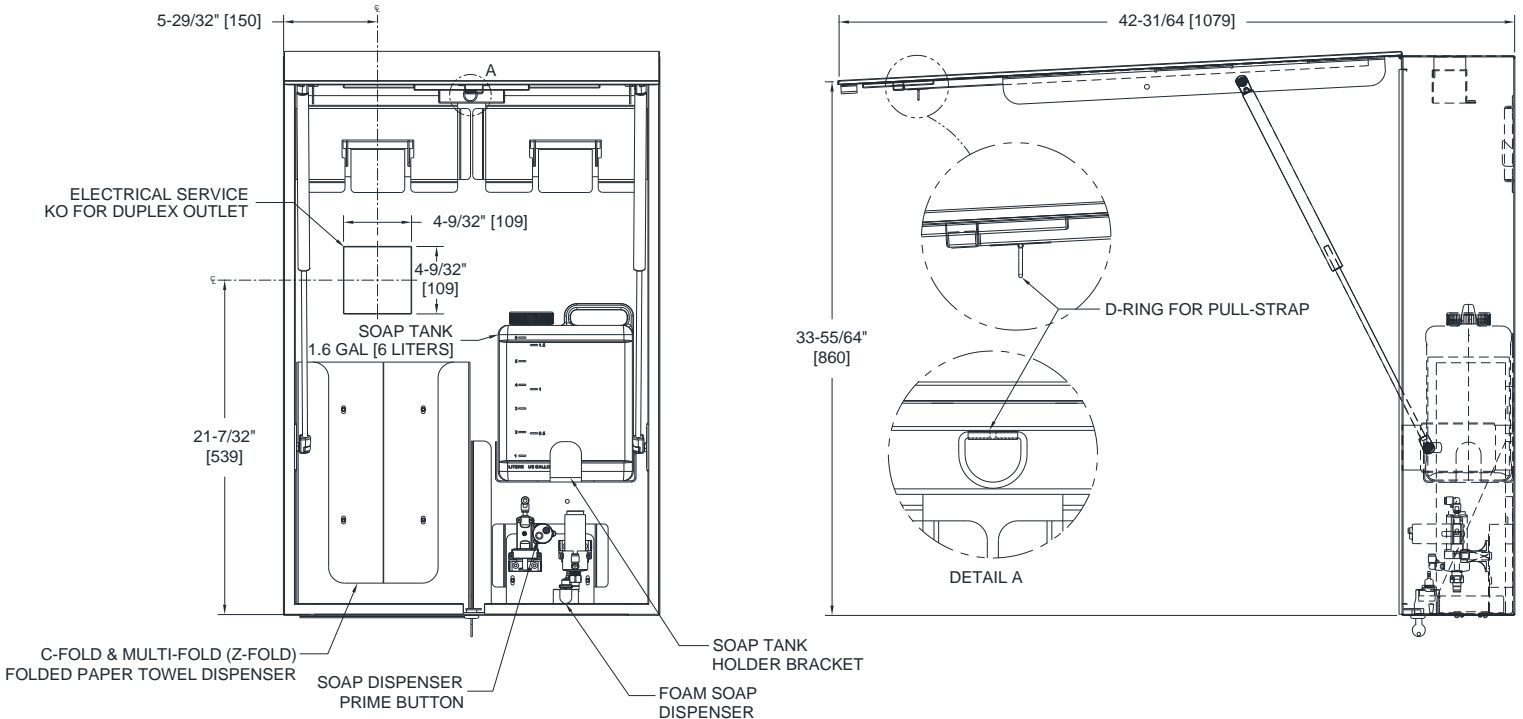

OPEN VIEW (-T)