

1 Description

The LCN Safety Module is designed to add a safety circuit to the LCN 4800 Series automatic door operators. The 8310-889 aids the Bodyguard Safety Scanner by determining door position. If the door is closed and there is something in the Bodyguard pattern, the Safety Module will stop the activation device from opening the door. If in the open position and the swing path is not clear, the Safety Module will allow the Bodyguard to hold the door open as long as the Bodyguard detects something.

The Safety Module provides an adjustable timer that blocks the Bodyguard Safety Scanner signal as it detects the door during its closing cycle, thereby allowing re-activation if necessary. This system is known as a dedicated or committed system. Consequently, if a person were to step back into the swing path of the door while the door was closing; the Bodyguard would ignore them, until the door reached a fully closed position, when the Safety Module would normally time out.

2 Specifications

DESCRIPTION	SPECIFICATION
POWER SUPPLY	12-24 VAC/VDC
OPERATING FREQUENCY	4 MHz (Microprocessor)
POWER CONSUMPTION	10 mA at rest; 50 mA Max.
OUTPUT	2 x SPST Relays
MAX. VOLTAGE - RELAY CONTACT	60 VDC; 120 VAC
MAX. CURRENT - RELAY CONTACTS	2.0A DC; 0.5A AC

3 Identification

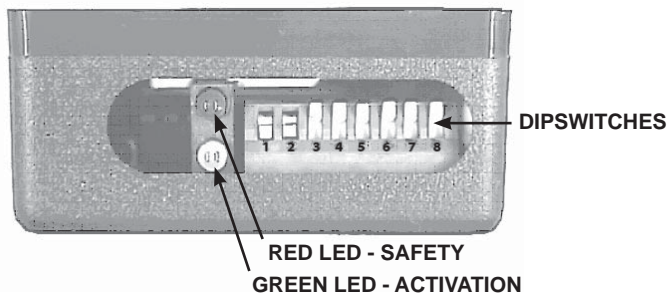

4 Precautions



- Shut off all power before attempting any wiring procedures.
- Maintain a clean & safe environment when working in public areas.
- Constantly be aware of pedestrian traffic around the area.
- Always stop pedestrian traffic through the doorway when performing tests that may result in unexpected reactions by the door.
- ESD electrostatic discharge: Circuit boards are vulnerable to damage by electrostatic discharge. Before handling any board ensure you dissipate your body's charge.
- Always check placement of all wiring before powering up to insure that moving parts will not catch any wires and cause damage to equipment.
- Ensure compliance with all applicable safety standards (i.e. ANSI A156.10 / 19) upon completion of installation.
- DO NOT attempt any internal repair of the sensor. All repairs and/or component replacements must be performed by LCN, Inc. Unauthorized disassembly or repair:
 1. May jeopardize personal safety and may expose one to the risk of electrical shock.
 2. May adversely affect the safe and reliable performance of the product will result in a voided product warranty.

5 Wiring

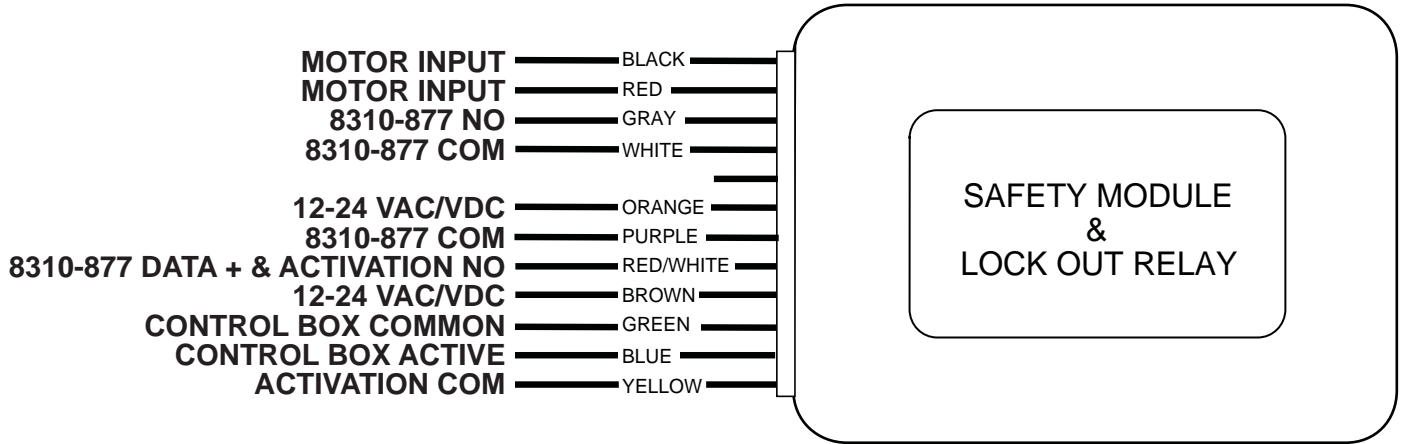

SAFETY MODULE HARNESS

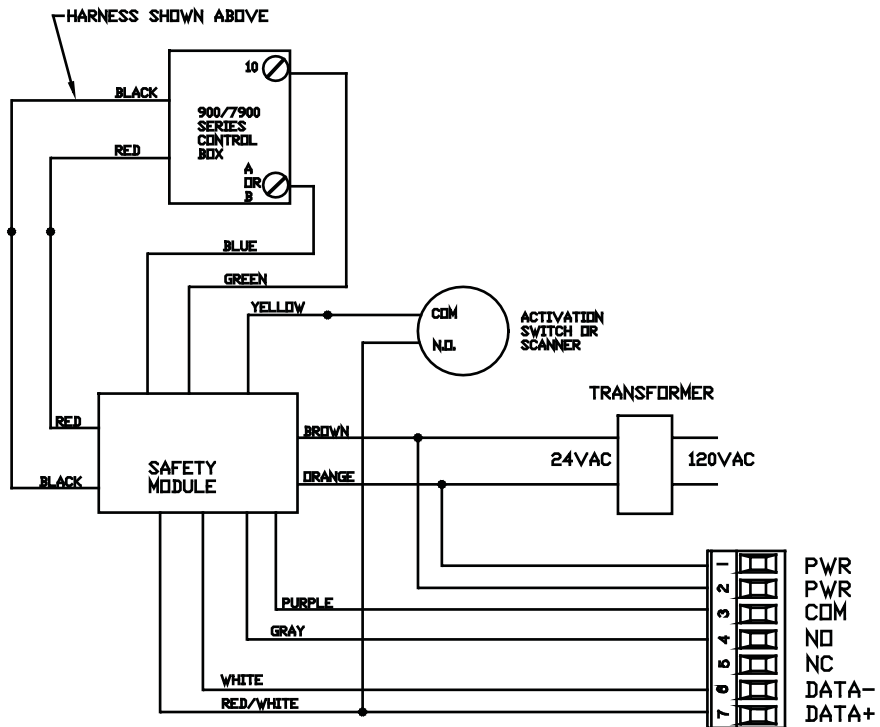

WIRING DIAGRAM

SAFETY SCANNER

6 Setup

- Once all components are properly wired together, apply power and begin the set-up process. The Safety Module has two LED's to indicate what function the Safety Module is currently performing. When the door is closed and someone steps into the safety zone, the Safety Module's red LED indicates that it will ignore any activation signal it receives. Therefore, the door will remain closed until the Bodyguard safety zone is clear. Once the safety zone is clear and the door has been activated, a normal opening cycle will commence.
- If someone steps into the safety zone when the door is open, the Safety Module's green LED will indicate that the Bodyguard will be connected to the activation circuitry of the door thus holding the door open for as long as someone is in its pattern.
- The lock out time delay for the door closing cycle must be set using the six dip switches located on the front of the unit. A 0 to 31 second lock out time delay can be achieved. The lock out time delay must be set so that the Bodyguard scanner does not send a safety signal during the closing cycle. As soon as the door reaches the jamb, the Safety Module should reactivate the Bodyguard.
- Check to make sure that the Safety Module locks out the Bodyguard for the entire closing cycle of the door. If the scanner sends a safety signal (scanner red light on) anytime during the closing cycle, the time delay set on the Safety Module must be increased. If the door goes into safety swing as soon as it starts to close and you have a time delay set for the length of the closing cycle, ensure that the AC power is being switched on and off at the point of connection for the red and black wires. Correct any faults before proceeding.
- Set the dip switches according to the chart below to achieve the desired lock out time delay. The dip switches are configured to send a binary coded input to the microprocessor to establish the correct lock out time delay.

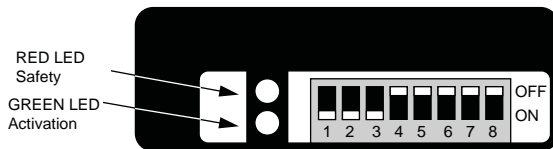

- Dip Switch 1 = 1 second
- Dip Switch 2 = 2 seconds
- Dip Switch 3 = 4 seconds
- Dip Switch 4 = 8 seconds
- Dip Switch 5 = 16 seconds
- Dip Switch 6 = Not used (must be in off position)
- Dip Switch 7 = Not used (must be in off position)
- Dip Switch 8 = Not used (must be in off position)

For Example:

The normal closing cycle of an automatic door lasts about 7 seconds. In order to get the proper closing lock out time delay needed for the closing cycle of the door, the dip switches need to be set according to the chart below for 7 seconds (Default Setting). To get the proper lock out time delay dip switches 1, 2, & 3 must be in the ON position and Dip Switches 4 thru 8 must be in the OFF position.

TIME DELAY (sec)	DIP 1 (1 sec)	DIP 2 (2 sec)	DIP 3 (4 sec)	DIP 4 (8 sec)	DIP 5 (16 sec)
1	ON	OFF	OFF	OFF	OFF
2	OFF	ON	OFF	OFF	OFF
3	ON	ON	OFF	OFF	OFF
4	OFF	OFF	ON	OFF	OFF
5	ON	OFF	ON	OFF	OFF
6	OFF	ON	ON	OFF	OFF
7	ON	ON	ON	OFF	OFF
8	OFF	OFF	OFF	ON	OFF
9	ON	OFF	OFF	ON	OFF
10	OFF	ON	OFF	ON	OFF
11	ON	ON	OFF	ON	OFF
12	OFF	OFF	ON	ON	OFF
13	ON	OFF	ON	ON	OFF
14	OFF	ON	ON	ON	OFF
15	ON	ON	ON	ON	OFF
16	OFF	OFF	OFF	OFF	ON

TIME DELAY (sec)	DIP 1 (1 sec)	DIP 2 (2 sec)	DIP 3 (4 sec)	DIP 4 (8 sec)	DIP 5 (16 sec)
17	ON	OFF	OFF	OFF	ON
18	OFF	ON	OFF	OFF	ON
19	ON	ON	OFF	OFF	ON
20	OFF	OFF	ON	OFF	ON
21	ON	OFF	ON	OFF	ON
22	OFF	ON	ON	OFF	ON
23	ON	ON	ON	OFF	ON
24	OFF	OFF	OFF	ON	ON
25	ON	OFF	OFF	ON	ON
26	OFF	ON	OFF	ON	ON
27	ON	ON	OFF	ON	ON
28	OFF	OFF	ON	ON	ON
29	ON	OFF	ON	ON	ON
30	OFF	ON	ON	ON	ON
31	ON	ON	ON	ON	ON

NOTE: Manual operation of the door will not affect the operation of the Safety Module, since there is no voltage being created to drive to Safety Module.

7 Company Contact



Do not leave problems unresolved. If a satisfactory solution cannot be achieved after troubleshooting a problem, please contact LCN at 1-800-526-2400. If you must wait for the following workday to call LCN, leave the door inoperable until satisfactory repairs can be made. Never sacrifice the safe operation of the automatic door or gate for an incomplete solution.

For more information, visit www.lcn.ingersollrand.com.