

- NOTES:
 1. FOR ADDITIONAL HANDLE INFORMATION SEE CATALOG PAGE #SW33.
 2. FOR CYLINDER GUARD SEE CATALOG PAGE #SW13.
 3. DIMENSIONS IN PARENTHESIS ARE IN MILLIMETERS.

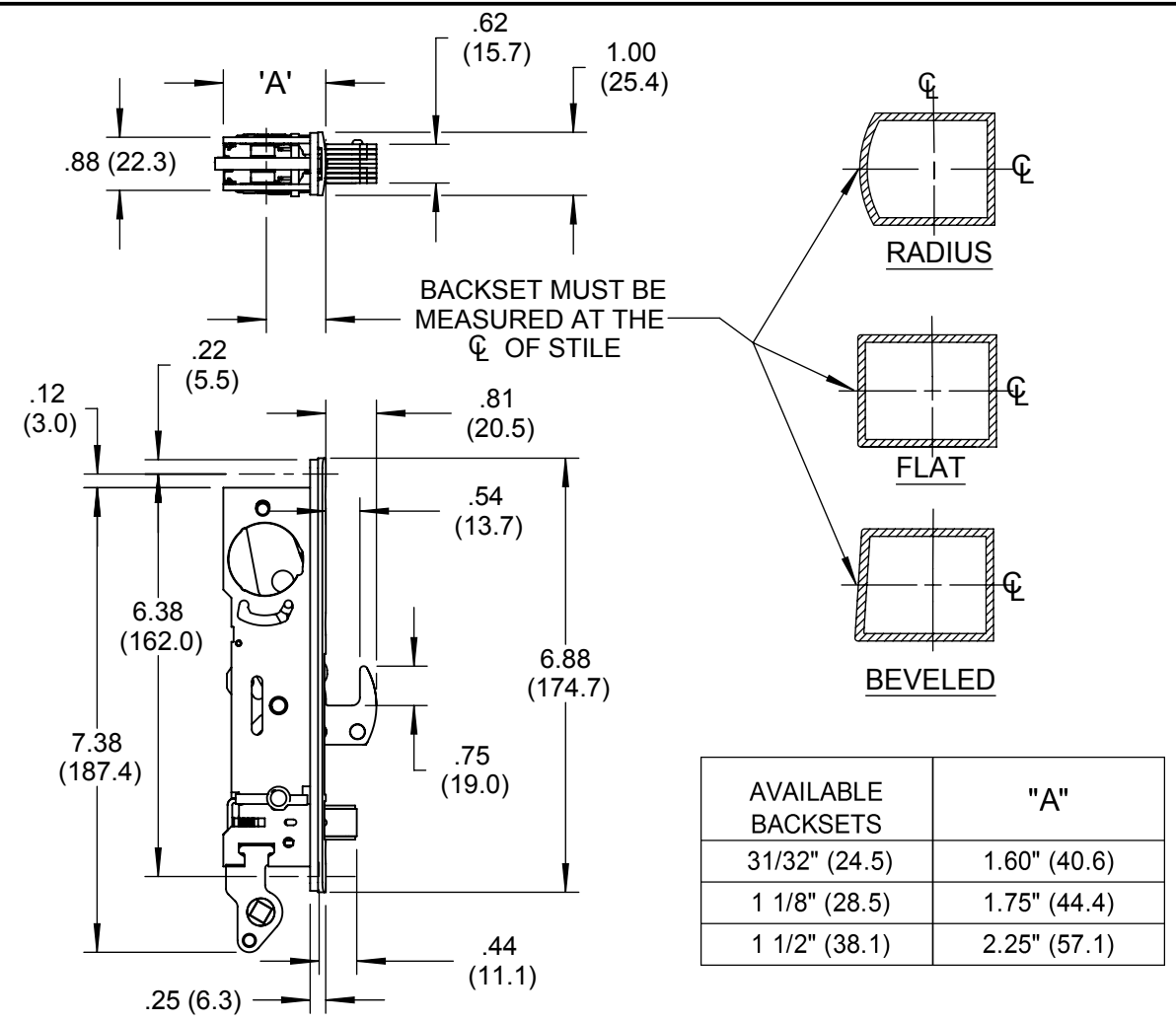

STRIKE APPLICATIONS

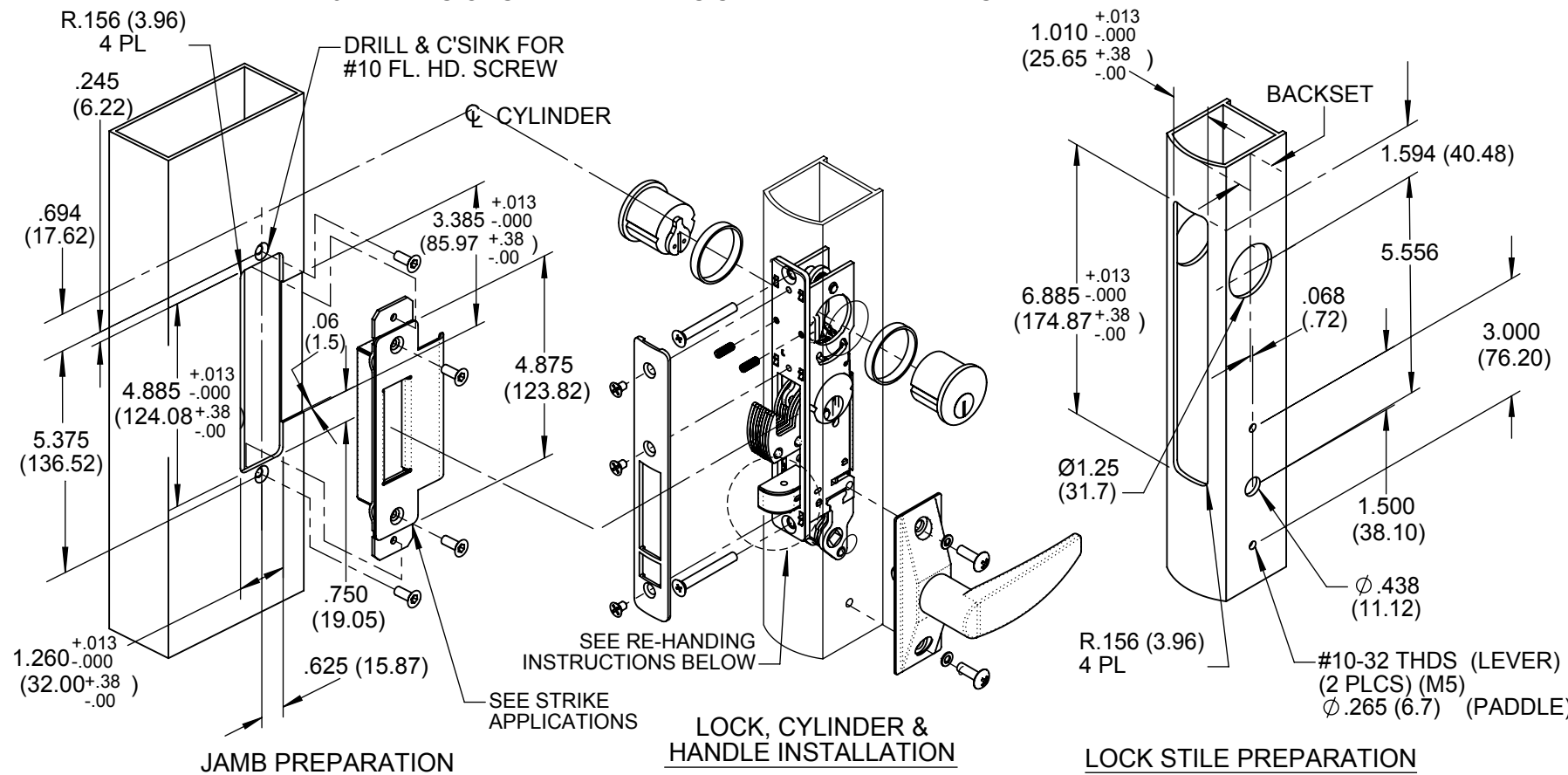
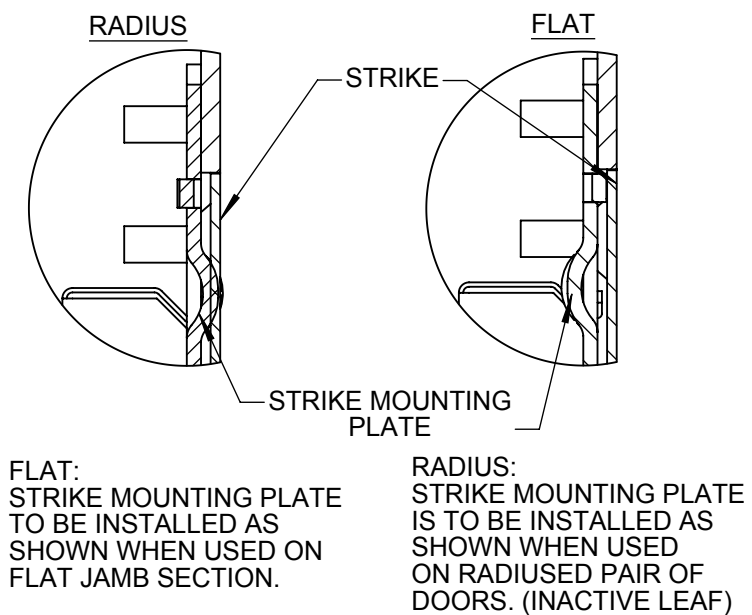

RE-HANDING INSTRUCTIONS

- USING ALLEN HEX KEY, LOOSEN THE SET SCREW AND REMOVE THE BOLT (FIG. 1)
- ROTATE 180°, INSTALL IT BACK AND RE-TIGHTEN THE SET SCREW (FIG. 2)

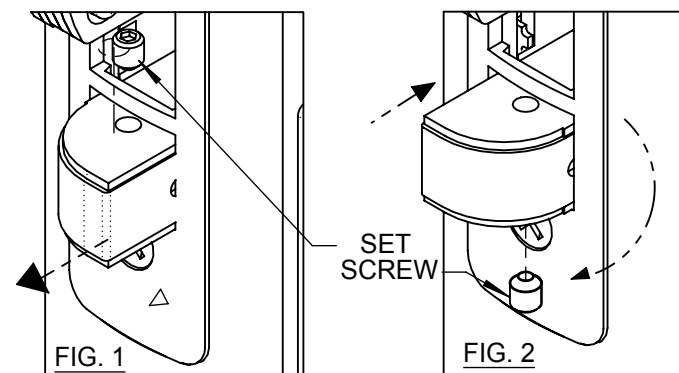

MOUNTING METHODS

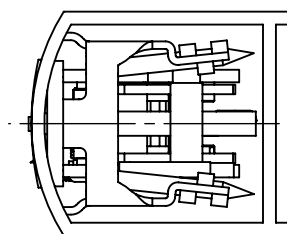

METHOD #1
 4104
 FOR MOUNTING INSTRUCTIONS SEE CATALOG PAGE #SW100

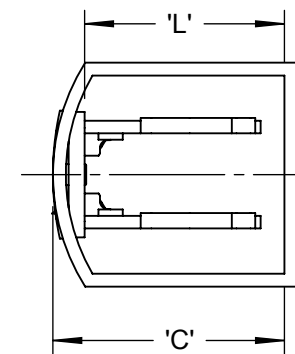

METHOD #2
 LOCK IS SECURED TO BACK WEB OF STILE BY MEANS OF #10 (M4) FLAT HEAD MACHINE SCREWS & TUBE SPACERS OF PROPER LENGTH TO POSITION LOCK. FOR TUBE SPACER LENGTH (L) USE THE FOLLOWING FORMULA:
 $L = C - .25 (6.35)$
 SCREWS FURNISHED WILL BE APPROX. 1/4" LONGER THAN THE SPACER.

AVAILABLE FACEPLATES

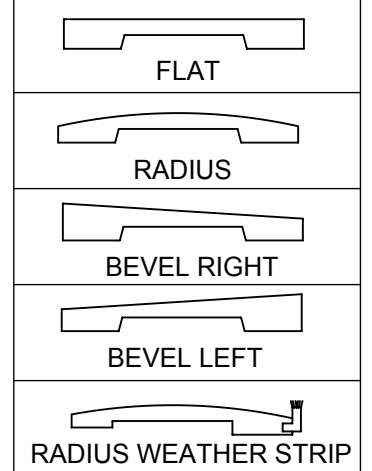

* MINIMUM SINGLE ACTION GAP 1/8" (3.1) WHEN USING WEATHER SEAL FACEPLATE