

LM Latch Monitors

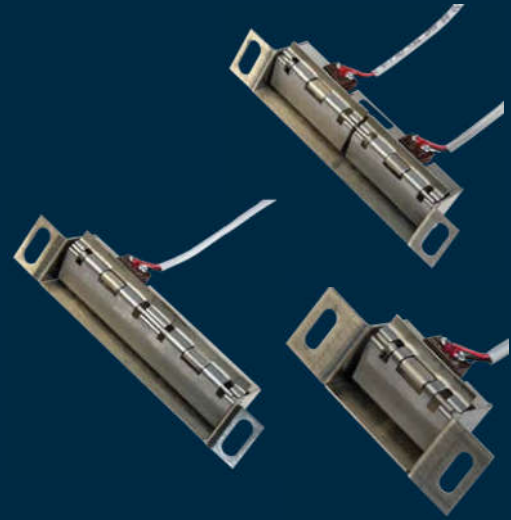

The LM Series interfaces with an access control or alarm system to indicate the state of the latchbolt.

Used alone or in conjunction with a door position switch, the LM provides confirmation that the door is secure, preventing false alarms and unauthorized access while providing tamper detection. Can also be used to transmit an initiate signal to XDT delayed egress logic timers.

Features

Standard Features

- Electronically detects and reports mechanical latch and bolt positions
- Provides peace of mind that the door is secure
- Installs easily, conceals behind existing hardware
- Requires no jamb or strike plate modification
- MagnaCare® lifetime replacement, no-fault, no questions asked warranty

Optional Features

- LML-1 provides SPDT switch, fits ANSI 4-7/8" [123.825mm] cutout
- LMS-1 provides SPDT switch, fits ANSI 2-3/4" [69.85mm] cutout
- LML-2 monitors mortise latch and deadbolt separately with two SPDT switches

Specifications

Certifications

- UL 634 Listed
- ULC/ORD-C634 Listed
- ANSI/UL 294 Listed
- CSFM — California State Fire Marshal Approved

Electrical

- Contact Rating: SPDT 2A at 24V

Environmental

- Operating Temperature: -40° to 160°F [-40° to 71°C]



Dimensions

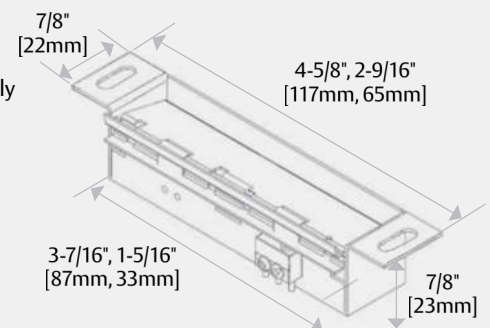

How to Order

MODEL SERIES	STRIKE SIZE	NUMBER OF SWITCHES
LM	L	-2
LM Latch Monitor	L ANSI 4-7/8" Strike	1 Single Switch
	S ANSI 2-3/4" Strike	2 Dual Switches



MagnaCare
Warranty

Updated 7/13/22 Printed in the U.S.A. Patent pending and/or patent www.assaabloydss.com/patents

Copyright © 2022, Hanchett Entry Systems, Inc., an ASSAABLOY Group company. All rights reserved. Reproduction in whole or in part without the express written permission of Hanchett Entry Systems, Inc. is prohibited.