



Insertion Card Reader Non-Lighted - IR1051F

IR1051F

Insertion Reader
 Mag Stripe
 Flush Mounted
 Environmental
 Non lighted

General Use:

MSLR1
 ATM access control

Electrical:

5VDC, 30mA

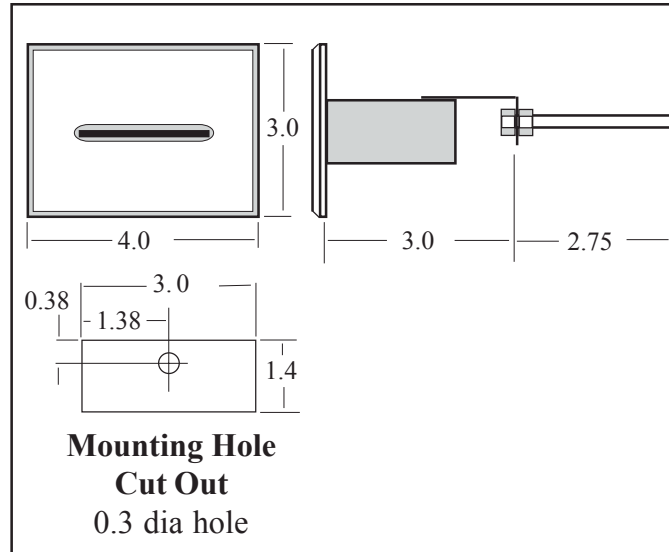

Mechanical:

Weight, 0.5 lbs.
 Color, Silver

Interface:

Cable distance 750ft.
 4 wire, 22 AWG,
 shielded cable.
 Ref: Belden 8723

