

4016

Header Bolt

Security for pairs of doors with single key turn is possible with the 4016 Header Bolt. The two-point locking solution secures the entire double door entrance when working in conjunction with an MS® Deadlock.

Function

Adding the 4016 Header Bolt to a pivoted bolt MS® deadlock provides Maximum Security for pairs of doors with the turn of a single key. Simultaneously extending the stainless steel hexbolts into the header and pivoting the massive MS® bolt into the mating door's stile, the two-point locking solution secures the entire entrance. The 4016 Header Bolt can be added to any basic MS1850S, MS1850SN, MS1950 Series deadlock or for two-points top and bottom use with 1870/1870HM Cylinder-Operated Flushbolt. Not applicable to 7/8" backset locks.

Both the 4016 Header Bolt and the 4015 Threshold Bolt may be added to a pivoted bolt MS® deadlock to provide Maximum Security for pairs of doors by the turn of a single key. Simultaneously extending the stainless steel hexbolts into the header and threshold and pivoting the massive MS® bolt into the mating door's stile, thereby providing a three-point locking solution.

Operation

360° turn of key or thumbturn in basic MS® deadlock throws counterbalanced bolt into opposite door and hexagonal bolt into header. Key can be removed only when bolts are in a positively locked or unlocked position.

Features

Door Height

Select 7' [2133.6 mm] or 10' [3048 mm] door height. The standard version is designed for 7' [2133.6 mm] door height, with cylinder height as low as 35" [889 mm].

Header Bolt

Hexagonal 3/8" [9.5 mm] flat to flat. Made of stainless steel.

Adjustment

Exact adjustment of threaded rod to door height is locked in place by hexagonal header bolt.

Strike

For header bolt, a 1/2" [12.7 mm] diameter hole in metal frame is suitable. For non-metal installation, 4005 Strike is available separately.

Standard Package

Packed separately with bolt guide, screws, and attachment pin.

Shipping Weight

1 lb [0.45 kg].



Lock available separately

All measurements are approximate and are provided for informational purposes only. Refer to the product Installation Instructions.

Dimensions

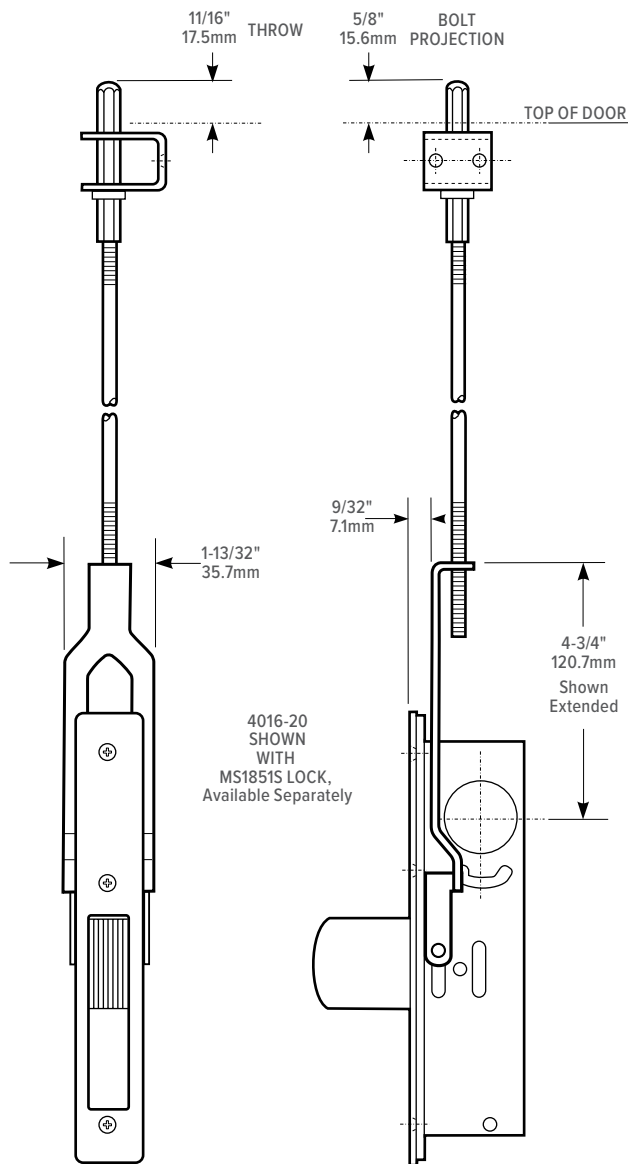

Installation

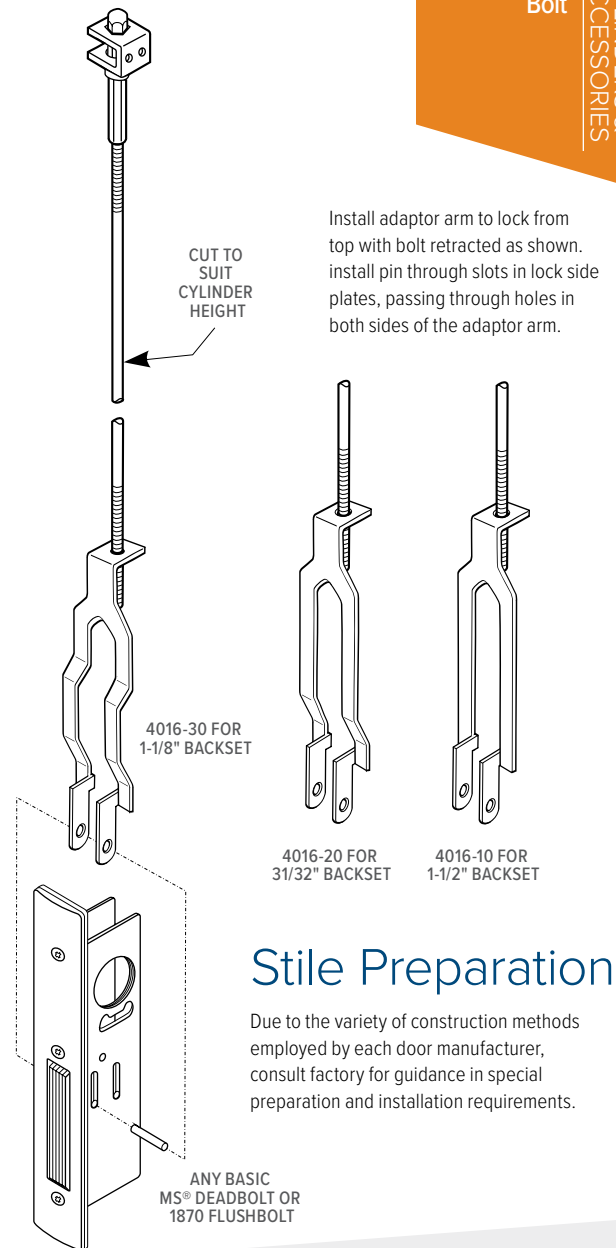

4016
Header Bolt

171
CYLINDERS &
ACCESSORIES

Stile Preparation

Due to the variety of construction methods employed by each door manufacturer, consult factory for guidance in special preparation and installation requirements.

How to Order, Related & Compatible Products

4016 Header Bolt Specify quantity and the following information. Order related products separately.

MODEL	LOCK BACKSET	DOOR HEIGHT
4016	-30	-01
	10 1-1/2"	01 7" Door
	20 31/32"	02 10' Door
	30 1-1/8"	

RELATED

When purchasing this product, please consider the following related products, available separately:

ACCESSORIES
4015 Threshold Bolt, 4085 Header Bolt

COMPATIBLE

DEADLOCKS	FLUSHLOCKS	ACCESSORIES
MS1850S, MS1850S-050, MS1850SN, MS1850SN-050, MS1950, MS1950-050 Series Deadlocks Not applicable to 7/8" backset locks.	1870, 1870HM Series Cylinder-Operated Flushbolts	4005 Strike

Experience a safer
and more open world

