

1601 MANUAL RELEASE KIT

DoorKing Part Number

1601-270

This kit is designed for the 1601 barrier gate operator **WITHOUT the convenience open** option. It provides an interlock power cut-off switch when manually using crank tool to move the arm up or down. **DO NOT install on convenience open models.**

Kit Includes: Pre-wired Interlock assembly,
Double motor pulley, Crank tool,
2 spring clips with lock nuts.

Installation

SHUT OFF the AC input power to the operator from the circuit breaker.

Mount spring clips with lock nuts on existing threaded studs inside access door.

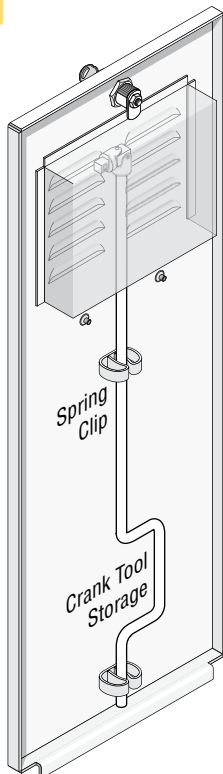

Replace existing single motor pulley with double motor pulley. Align motor pulley with gear reducer pulley.

Mount interlock assembly using existing hardware.

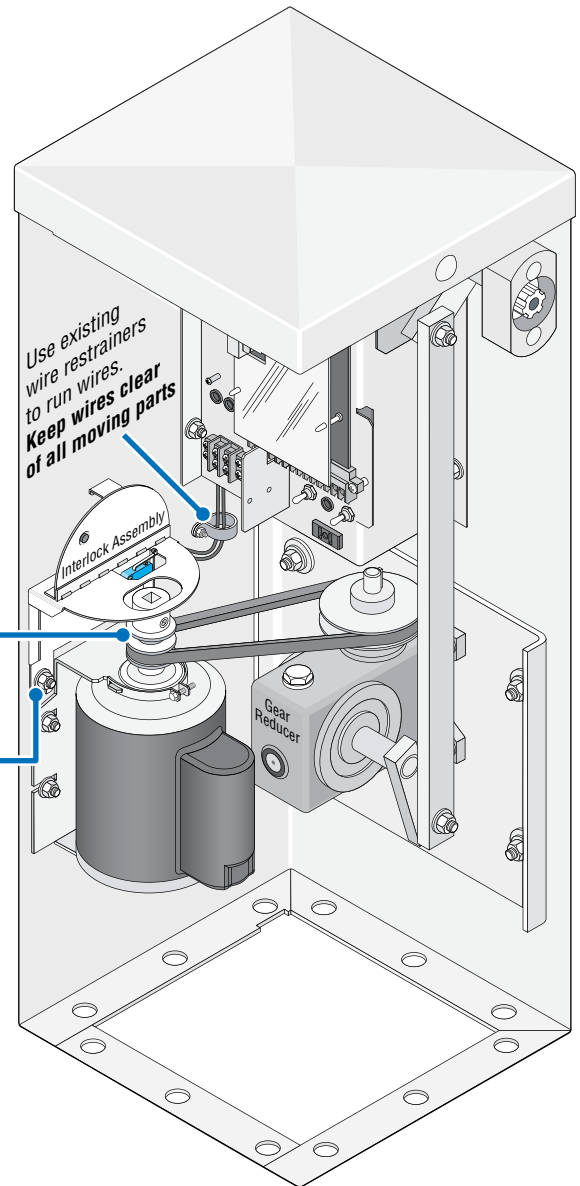

Wiring ONLY Interlock Switch

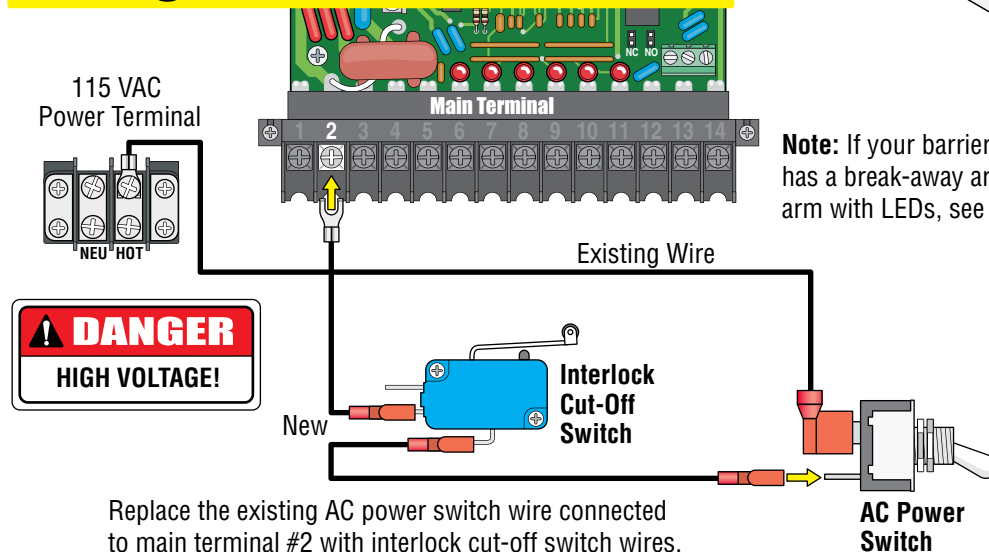

Note: If your barrier gate operator has a break-away arm or break-away arm with LEDs, see reverse side.

DKS
DOOR KING
120 S. Glasgow Avenue
Inglewood, California 90301 U.S.A.

Manual Operation

1. Unlock and remove access door.
2. Remove crank tool from inside access door.
3. Flip interlock assembly door up, power will be disabled from operator.
4. Insert crank tool into motor pulley as shown.
5. Rotate crank tool to manually move operator arm up or down.

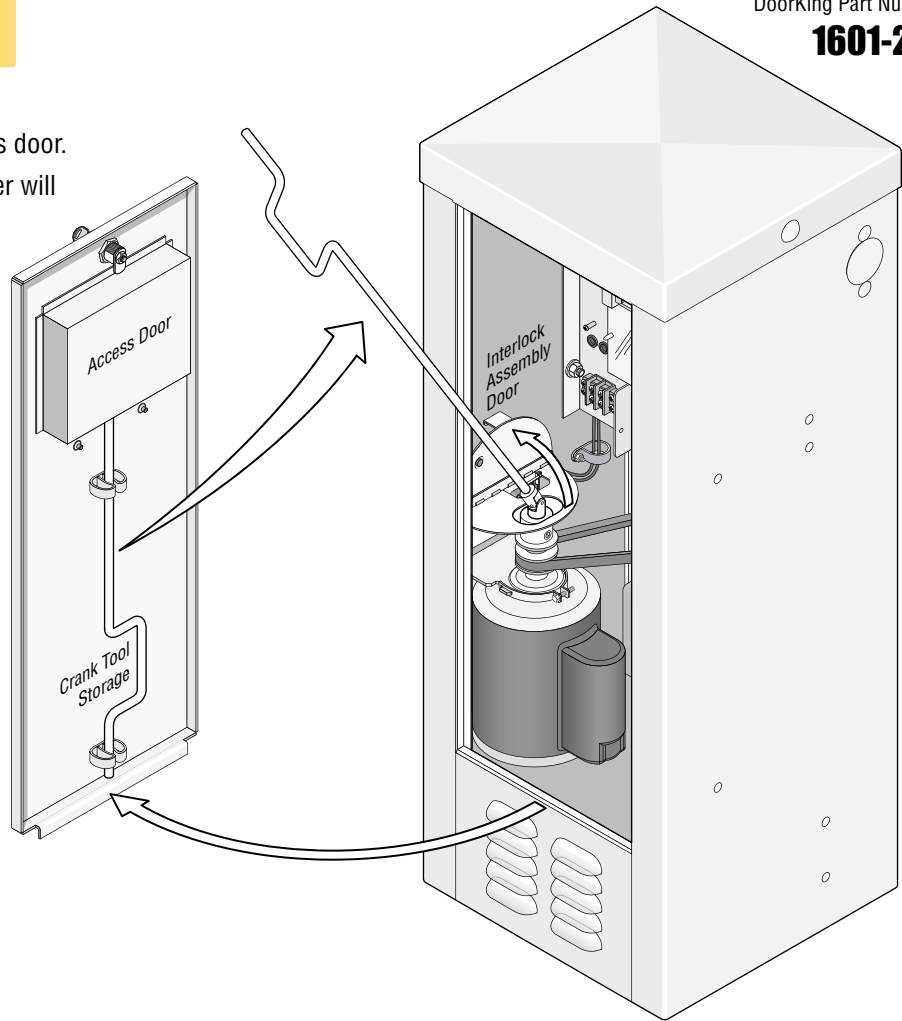

Wiring Interlock AND a Break-Away/LED Arm TOGETHER

If your 1601 has a Break-Away Arm and you want to add the manual release interlock, both can be wired together as shown.

