

## **US** User manual Verti 840 - US English



### **US** Products

**ADA Compliant Wall Cabinet Lift System**  
Wall Cabinet Lift - Granberg Verti 840

1. Important safety instructions / Introduction
2. ETL certification and declaration of conformity with EU directives
3. Intended use
4. Operating instructions
5. Technical data
6. Safe use
7. Safety arrangements
8. Load distribution and side forces
9. Actions after use
10. Instructions for recycling
11. Spare parts list

# 1. Important safety instructions / Introduction

## IMPORTANT SAFETY INSTRUCTIONS

When using an electrical furnishing, basic precautions should always be followed, including the following:  
Read all instructions before using the VERTI.

### DANGER

To reduce the risk of electric shock:  
Always unplug this furnishing from the electrical outlet before cleaning or servicing.

### WARNING

To reduce the risk of burns, fire, electric shock, or injury to persons:

1. Unplug from outlet before putting on or taking off parts.
2. Close supervision is necessary when this furnishing is used by, or near children.
3. Use this furnishing only for its intended use as described in these instructions. Do not use attachments not recommended by the manufacturer.
4. Never operate this furnishing if it has a damaged cord or plug, if it is not working properly, if it has been dropped or damaged, or dropped into water. Return the furnishing to a service center for examination and repair.
5. Keep the cord away from heated surfaces.
6. Never operate the furnishing with the air openings blocked. Keep the air openings free of lint, hair, and the like.
7. Never drop or insert any object into any opening.
8. Do not use outdoors.
9. Do not operate where aerosol (spray) products are being used or where oxygen is being administered.
10. To disconnect, turn all controls to the off position, then remove plug from outlet.
11. **WARNING:** Risk of injury - Keep children away from extended foot support (or other similar parts).
12. **WARNING:** Risk of Electric Shock - Connect this furnishing to a properly grounded outlet only.
13. For loading always put heavier items at the bottom and not near the top in order to help prevent the possibility of the furnishing tipping over.

### SAVE THESE INSTRUCTIONS

## INTRODUCTION

We have the pleasure to deliver a Granberg Interior Verti lift unit for installation in wall cabinets.

This is an electrically operated lifting and lowering system for installation in new or existing wall cabinets. It can be used separately, or together with the Granberg work top units, and it becomes then a total adaptation of the kitchen. The lift is suitable for all wall cabinets of various makes, which are made according to the standards EN 1116 and EN 1153.

### Only authorized persons may use the Verti!

Authorization means obligation to read and follow the instructions.  
It is very important that you read and understand the instructions before you use Verti.

If you have any questions - contact your supplier.

This instruction manual shall be available for all concerned persons, be kept in a protected place and shall follow the product, if it is moved to another installation site or another house or apartment owner.

**Correct use, operation, inspections and maintenance are decisive for efficient and safe work.**

## 2. ETL certification and declaration of conformity with EU directives

### ETL-Certification:

This product has been tested and certified by Intertek which is an independent third party organization accredited to issue a mark of ETL certification.

### CE-mark:

This product is CE-marked and is thereby declared to conform to the basic functionality and safety requirements of current Machinery, EMC and Low Voltage Directives.

## 3. Intended use

The Verti Cabinet lift unit is intended to achieve a convenient location to put or pick of normal kitchen cabinet items, e.g. dry groceries and household objects, by means of manoeuvring the shelf system vertically. Verti is mounted in a kitchen cabinet of massive wood or of lacquered or laminated chipboards. The operation shall be indoors, under normal housing conditions regarding temperature, humidity and lighting.

Verti is not intended for use in moist environments.

The Verti Cabinet lift unit is delivered for installation in a new cabinet frame, comprising sides and a top board, or for installation in existing cabinet. The shelves and the bottom board must be demounted before the Verti is installed.

It is assumed that the wall cabinet is made according the standards EN 1116 and EN 1153.

## 4. Operating instructions

Verti is an electrical system that raises and lowers cupboard shelves quickly and silently to or from the work surface.

1. Press and hold the button to start the operation.
2. Release the button when the shelves are at the desired level.

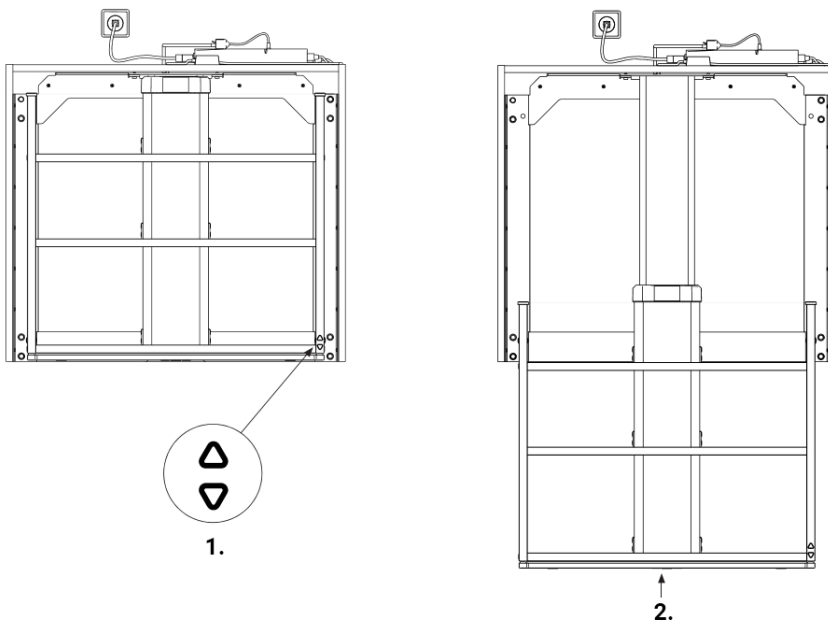

**1** = UP / DOWN

**2** = Safety stop

## 5. Technical data

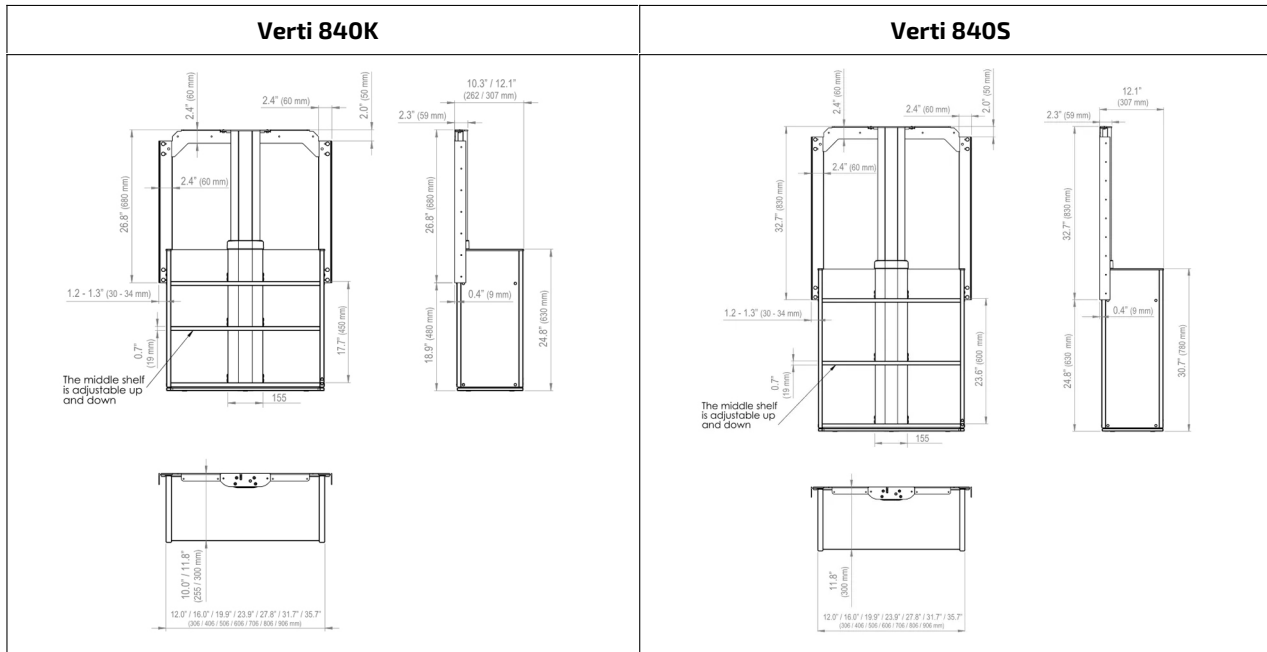

	<b>840KA</b>	<b>840KB</b>	<b>840SB</b>
<b>Cabinet width (inside)</b>	14.2" - 37.8" (360 - 960 mm)	14.2" - 37.8" (360 - 960 mm)	14.2" - 37.8" (360 - 960 mm)
<b>Width of shelves</b>	11.4" - 35.0" (290 - 890 mm)	11.4" - 35.0" (290 - 890 mm)	11.4" - 35.0" (290 - 890 mm)
<b>Cabinet height</b>	27.6-33.0" (700-840 mm)	27.6-33.0" (700-840 mm)	Min. 33.5" (850 mm)
<b>Cabinet depth, min</b>	10.5" (267 mm)	12.3" (312 mm)	12.3" (312 mm)
<b>Depth of shelves</b>	9.4" (240 mm)	11.2" (285 mm)	11.2" (285 mm)
<b>Vertical stroke, max</b>	19.1" (485 mm)	19.1" (485 mm)	24.8" (630 mm)
<b>Time for a lift or lowering stroke, approx.</b>	12 s.	12 s.	16 s.
<b>Mains voltage*</b>	Plug for 110 V	Plug for 110 V	Plug for 110 V
<b>Consumption</b>	Max 5A, 1150W	Max 5A, 1150W	Max 5A, 1150W
<b>Max no. of full work cycles / hour</b>	6	6	6
<b>Control voltage</b>	5 V DC	5 V DC	5 V DC
<b>Weight including shelves, max. size</b>	57.3 lb (26 kg)	57.3 lb (26 kg)	59.5 lb (27 kg)
<b>Max load in a cabinet</b>	132 lb (60 kg)	132 lb (60 kg)	132 lb (60 kg)
<b>Noise pressure</b>	< 70 dB(A)	< 70 dB(A)	< 70 dB(A)

\* The voltage depends on which model that is delivered.

## 6. Safe use

In order to utilise the properties of Verti lift and to prevent and avoid damages it is important that you carefully read the instructions and operates it in the right way.

- Only use the Verti for its intended purpose.
- The operation and use must be made in such way that there is no risk for damages on persons and property.
- Be aware of that you as an operator are responsible for that nobody is damaged.
- The lift and the work area must be in proper condition. The Verti must not be used if any fault has appeared which influences the functions or the operation safety. It shall also not be used if it has been repaired, altered or adjusted without permission of a responsible person.
- The Control devices shall be placed so that the operator has got full view over Verti and its work area when operations are made.
- Never let the Verti come in contact with adjacent objects.
- Safety devices must not be taken out of service or removed.
- Alterations of the Verti that influence the operational safety or the functions are not allowed.
- Decals and markings must not be removed or made illegible.
- Use safe and sufficient lifting methods, when handling load to and from Verti. In particular beware when handling heavy items, and goods with hazardous content or with sharp corners and edges.
- The Verti unit shall regularly, once a year, be inspected in order to prevent accidents.
- Applicable Building and Safe use Regulations must be complied with.
- It is forbidden to stay in wall the cabinet, to hang in the cabinet shelves or to use the lift for lifting of persons.
- Do not use the Verti as a lifting jack, e.g. for lifting from the floor.
- The machine must not come in direct contact with food
- Do not use the Verti in a potentially explosive environment.
- When the operation is in a public location, particularly when children can enter the work area, the operator shall make satisfactory arrangements to prevent persons from entering the hazardous area when the lift is being operated, or it has been lowered from the parking position, e.g. by means of blocking the work area or by means of adding protection devices.
- During inspections, service and repair work there shall be no load in the cabinet. It can be necessary to demount the shelves from the lift to carry out service or repair.
- Competent persons only must carry out Installation, service and repair works. Only Granberg original spare parts shall be used when replacing any parts. Our warranty commitment can otherwise be invalidated.

### **Placement of household items.**

Place the goods in good order with the most frequently used at the lower part of the cabinet. Make sure that the objects do not extend outside the shelves. Mind that the objects may roll, slide or fall out of the cabinet. Spread out light and heavy items so that the weight is uniformly distributed and balanced on the shelves.

### **Suitable items to be placed in Verti**

In the cabinet you can keep e.g.: crockery, drinking glasses, bowls, cups, and mugs, groceries in hard packages.

### **Unsuitable items**

Saucepans, fry pans and other items with projecting long handles. Cutlery and other small loose items, unless they are placed in stable holders. Fluids, e.g. drinks in soft packages. Items packed in soft plastic or papers bags. Carving knives.

### **Acceptable height for objects placed on the upper shelf**

The max. height of objects on the upper shelf is 5.5" (14 cm).

### **Running up or down**

The Verti unit lowers or raises the shelves in a vertical movement to or from a work area under it. Operation is made with the buttons UP respectively DOWN (marked with arrows for the resp. directions). The movement continues as long as the button is kept pressed, or to until the end position is reached. Only press the button for the desired direction. Do not touch any part of the lift, cabinet or the shelves during operation.

### **Only operate one lift unit at a time**

If the kitchen contains more than one lifting unit you may only operate one lift at a time, to make sure of that you have full control over the movements.

### Operation with open or closed cabinet doors

The cabinet doors may be open or closed. Observe the following:

- Open doors: Increased risk that instable items will fall out from shelf.
- Closed doors: Make sure that no items are projecting outside the shelves as these can be tripped by the bottom edges of the cabinet doors.

### If any fault occurs

If tripping or any other fault appears during operation the control button shall be released immediately, so that the movement is stopped. If driving in opposite direction will rectify the fault, such action is acceptable.

If the fault is of any other kind, such as that the cabinet lift unit moves without a control device is pressed, the electric feed shall be broken immediately, by means of removing the electric plug from the wall socket, or to switch off the main switch. Then call the installer for repair.



Do not lower the Verti the space below it is free from persons or obstacles. In particular if the Verti unit is installed above a workbench with adjustable height there is an imminent risk that you do not notice objects or equipment that might be trapped.



At lifting with closed cabinet doors there is a risk to be trapped between a shelf and a door or if an object is placed too far out on the shelf it may come in contact with the cabinet door.

Do not put hands, arms, or any other part of the body or any object into the Verti unit when the shelves are in motion.



Do not load items above the side edge.

## 7. Safety arrangements

Below the bottom shelf there is a fully covering safety trip plate with reversal operation. If the trip plate is pressed the Verti will lift until the obstacle that activated the movement does not actuate the trip plate any longer.

Be aware of that the trip plate requires a certain force to become activated, so too brittle objects may break before the safety plate has been pressed in. The trip plate function shall be check often.

## 8. Load distribution and side forces

### Basic loading requirements:

- **100 % of the rated load distributed over the entire cabinet volume.**
- **The Centre of Gravity of the load is assumed to be in or under the cabinet centre.**
- **Horizontal forces are not allowed.**

Horizontal forces can appear, for example, when pressing onto the shelves or the load. It is difficult to estimate the size of the actual horizontal force, so utmost care must always be taken.

Further to the incorporated safety arrangements additional can safety actions may be required on or at the Verti lift. Discuss suitable actions with your Granberg representative or with the health and safety inspection.

We recommend that a Risk assessment in accordance with the Machinery Directive shall be made for the actual working conditions.

If the owner fits accessories, contact Granberg to get approval of the loading conditions.



Incorrect load distribution!



Correct load distribution!

## 9. Actions after use

The Verti unit shall after use be left fully raised to the top level, the parking position.

Switch off the main switch and lock it in closed position, if unauthorized use can occur. To prevent unauthorized use can it is also possible to furnish the control panel with a key switch, by means of which the control circuit is disconnected. It can also be placed inside a lockable cabinet.

## 10. Instructions for recycling

When the Verti unit shall be re-used shall it must be cleaned, inspected and go through a full operation test before it is installed on the new site.

We recommend the machine to be sent to Granberg or to the Granberg distributor to get this done.

The machine is manufactured from re-usable materials or from materials that can be recycled.

## 11. Spare parts list

If any component does not work or has broken, contact your supplier. Only Granberg original spare parts must be used when replacing any parts. Our warranty commitment may otherwise be invalidated.

### **Return of spare parts:**

Contact Granberg prior to any return of parts.

Do not return any parts that have been worn out during normal operation or accidentally damaged. Only return worn or damaged parts if it is considered that the fault is covered by our warranty conditions. In such cases, return the parts without delay, otherwise the right to replacement may be lost.

When ordering spare parts always quote the manufacturing number and type.