

DW#	B1-TP10	PH2 - PAN - TP-A	Revision Record			
-----	---------	------------------	-----------------	--	--	--

Part No	Nominal Length	L	
		Inch	mm
	7/16"	0.39"~0.44"	10.1~11.1

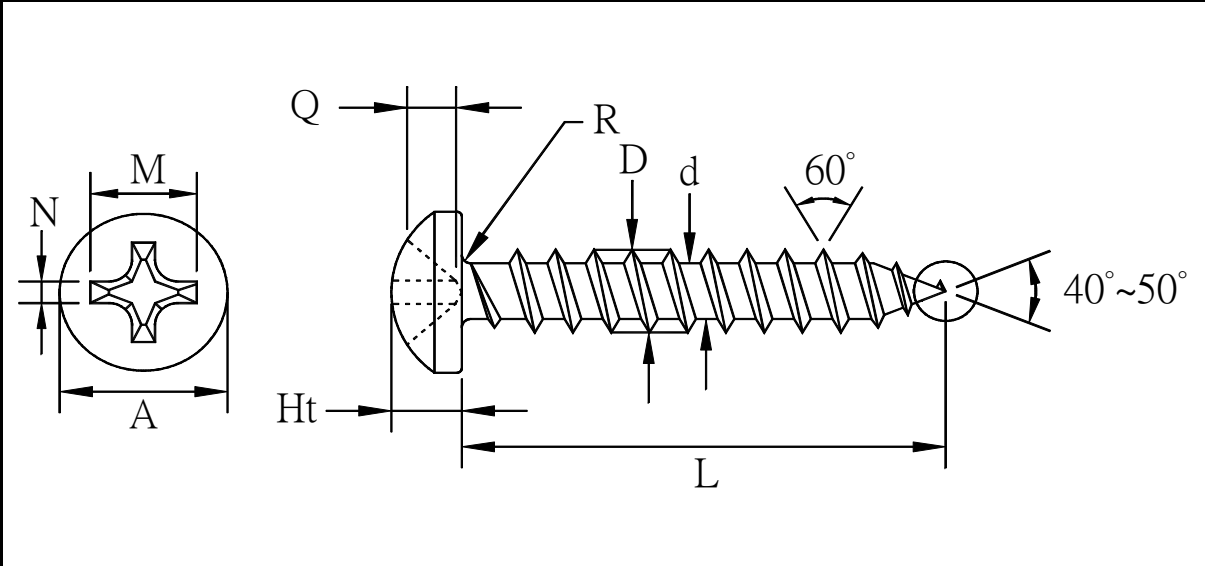

Date	Dim./Spec.	Old	New

Unit	Size /Thrds	A	M	N	Ht	Gage		R	D	d	Wire	Torque
						Phillips						
						Recess	Q					
Inch	#6-18	0.271"	Min.	Min.	0.083"	#2	0.080"	Max.	0.141"	0.102"	0.110"	24
		0.255"	0.153"	0.028"	0.074"		0.066"	0.020"	0.135"	0.095"		lbf.in
mm		6.86	Min.	Min.	2.10	#2	2.03	Max.	3.58	2.58	2.80	28
		6.50	3.89	0.72	1.90		1.68	0.50	3.45	2.42		kgf.cm

Specification:
Material: SAE C1022
Recess: #2 Phillips
Head: Pan head
Thread: Type A (IFI)
Heat Treatment: Surface Hardness:Min. HV446; Core Hardness:HV286~372
 Bending Angle: > 15° Breaking
 Case Depth:0.10~0.23mm
Surface: Zinc

Customer approve:	
w/date	
Approved by :	
w/date	
CAD by :	
w/date	
Issued date :	year-month-day
w/date	