

# Drawer Dimensions(mm)



Drawer material: Max. 16mm

LW = Internal Cabinet Width

SKW = Internal Drawer Width

\*The tolerance needs to be applied on the formula result. In other words, the drawer can be wider but cannot be narrower.

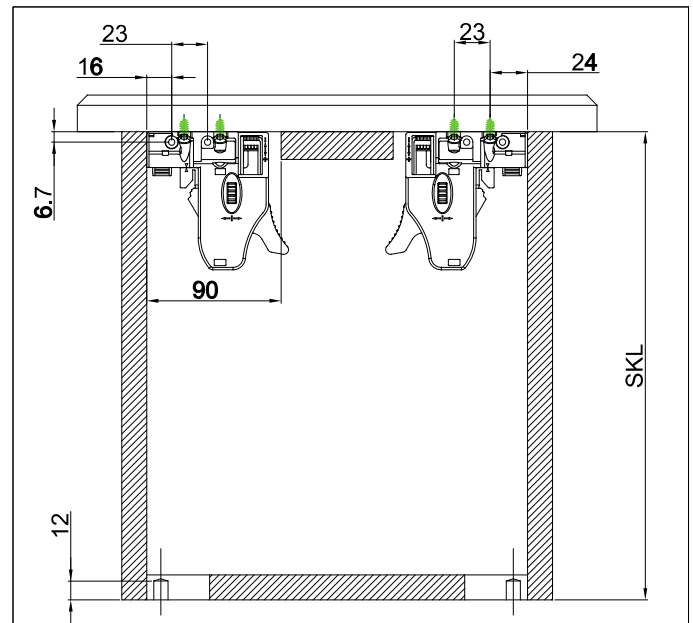
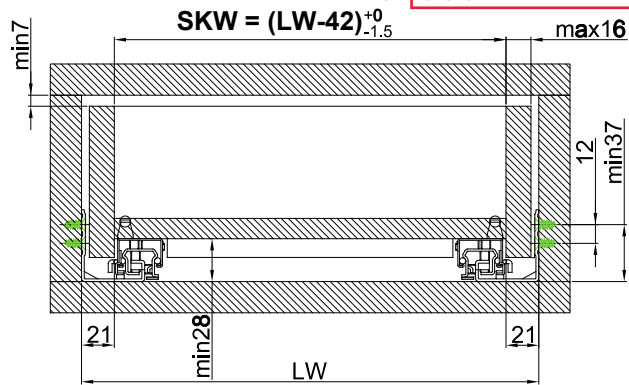

SKL = Drawer Length

LT = Inside Cabinet Length (Min.)

$LT = SKL + 18$

$SKL = NL - 10^*$

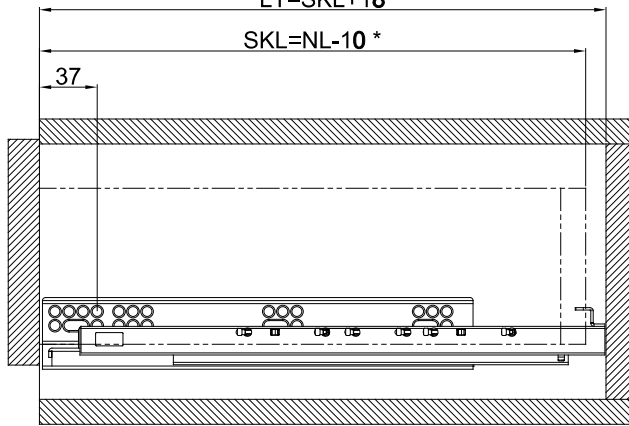

\* Except #828270

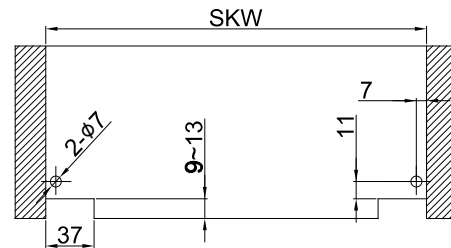

Item #	828270	828300	828350	828400	828450	828500	828550	828600
Slides Nominal Length (NL)	270	300	350	400	450	500	550	600
Drawer Length (SKL)	270	290	340	390	440	490	540	590
Inside Cabinet Length (min) (LT)	288	308	358	408	458	508	558	608

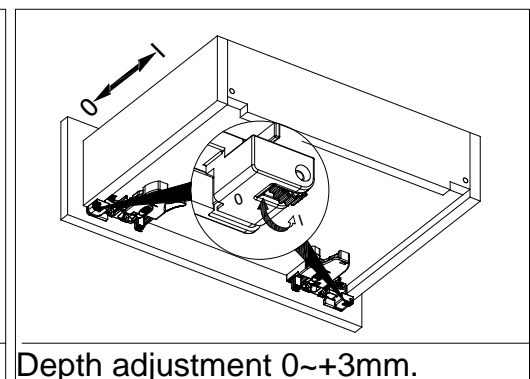
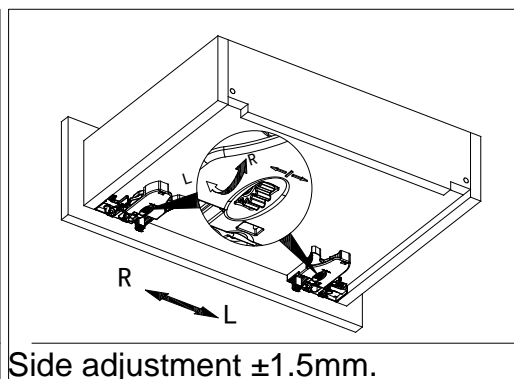
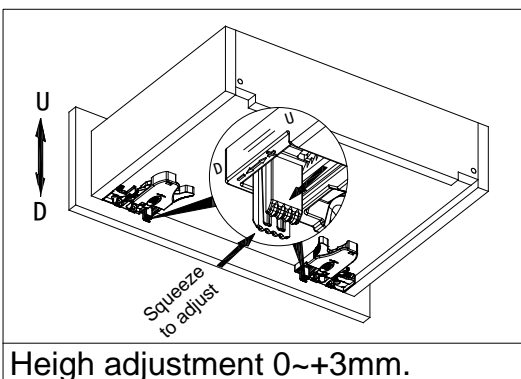

\* Side adjustment ±1.5mm, provided that drawer dimensions are within tolerance.