

CONTINUOUS GEARED HINGE

FULL SURFACE

1/16" DOOR INSET FOR 1 3/4" TO 2 1/4" DOORS

HD5700

Continuous geared aluminum hinges run the full height of the door evenly distributing the weight of the door along the full height of the frame. Ideal for high-frequency and heavy-weight doors in new construction and retrofit applications.

- ▶ Aluminum alloy 6063-T6; Anodized after machining
- ▶ Specially designed involute intermeshing gears
- ▶ Proprietary Teflon infused self-lubricating wear resistant bearings
- ▶ No hinge reinforcement necessary except on extremely heavy, extremely high-frequency or extra-wide doors
- ▶ Lifetime of the door opening warranty
- ▶ Frame leaf: #12-24 TEK flat head MS
- ▶ Door leaf: #12-24 TEK pan head MS and 1/4"-20 thru-bolts
- ▶ Standard lengths: 83", 85", 95", 119"

Available Options:

- ▶ #12 x 1 1/2" Wood Screws
- ▶ Torx Security TEK & T.B. M.S.
- ▶ 1 1/2" Torx Security Wood Screws
- ▶ Cut to Net Length - Specify Door Handing
- ▶ Anti-Ligature Hospital Tip - Specify "TIPIT-LG"
- ▶ Dutch Door Prep - Specify Door Handing, Top Door Leaf Length, and Clearance Between Leaves

Finishes:

A - Anodized Aluminum
DKB - Dark Bronze Anodized



Fire-rated 90-minute on hollow metal (except steel stiffened) or wood door leaves up to 4'0" x 7'2".



ANSI/BHMA Certified to A156.26 American National Standard for Continuous Hinges:
Grade 1 - 150 lb. Door
Grade 1 - 600 lb. Door

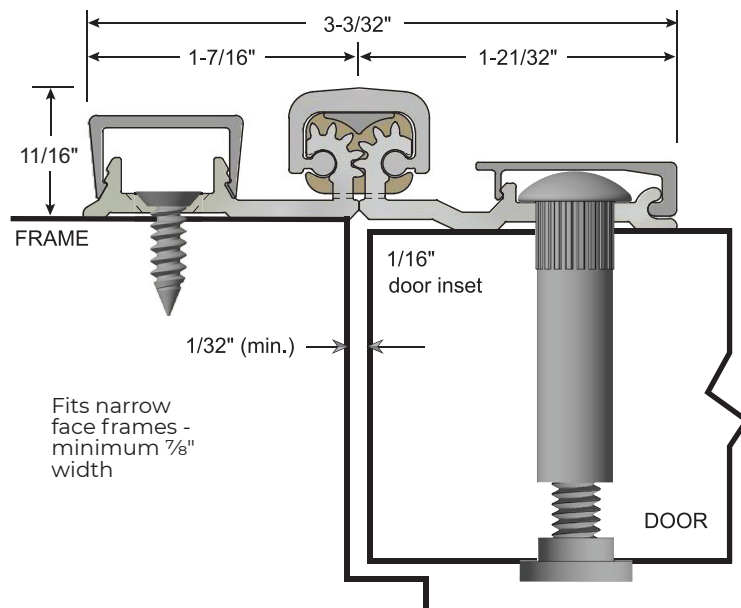

Concealed fastener covers on both leaves

