

# DTK-120/240CM+

## 120/240VAC Surge Protective Device General Product Specifications

DITEK's 120/240CM+ is a durable, cost-effective SPD suitable for use in a variety of locations. It is typically used to protect pumps, motors, HVAC condensers, and incoming utility power. Backed by a ten year warranty, the DTK-120/240CM+ is an excellent choice for effective, economical protection.

### DTK-120/240CM+ MORRIS# 89114

#### Product Features

- Weatherproof enclosure
- Parallel connection for easy installation
- Diagnostic LED provides positive indication of power, ground presence, and surge protection
- Automatically resets to handle multiple surge events
- Typical Applications: A/C disconnect, small electrical panels, pool/well pumps
- Ten year limited warranty

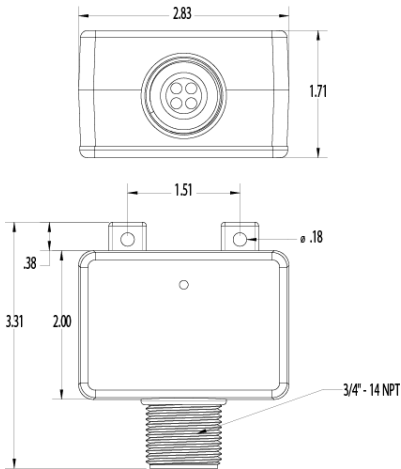

#### Specifications

**Agency Approvals:** UL 1449, 3<sup>rd</sup> Edition, cUL  
**Protector Type:** SPD Type 2  
**Protection Modes:** L-G, L-L  
**Response Time:** <1ns  
**Temperature Range:** -40°F – 185°F (-40°C – 85°C)  
**Maximum Humidity:** 95% non-condensing  
**Operating Frequency:** 0Hz – 400Hz  
**Dimensions:** 2.93" x 2.83" x 1.68"  
 (74.4mm x 71.9mm x 42.7mm)  
**Connection:** 3/4" threaded fitting  
**Weight:** .5lb. (227g)  
**Housing:** ABS

MORRIS# 89114	Service Wiring	Peak Surge Current	MCOV	UL 1449, 3 <sup>rd</sup> Ed. V.P.R.	Short Circuit Current Rating	UL1449, 3 <sup>rd</sup> Ed. I <sub>n</sub> Rating
DTK-120/240CM+	Split $\Phi$ (2W + G), 120/240VAC	72,000A/Phase 36,000A/Mode	130/260V	500V L-G, 900V L-L	10,000A	10,000A



DITEK Corporation  
ONE DITEK CENTER  
1720 Starkey Road  
Largo, FL 33771



# INSTALL INSTRUCTIONS

DTK-120/240CM+ MORRIS 89114

INSTALLATION

This Surge Protective Device (SPD) is a high performance device, designed to provide protection for sensitive electronic loads connected to service panels, fire panels, or where the SPD is directly connected to the electronic device. Maximum protection will only be achieved if the SPD is properly installed.

Please read and follow the installation instructions carefully.

**NOTICE:** This SPD should be installed by a qualified electrician in accordance with the National and Local Electrical Codes and the following instructions.

## APPLICATION

Type 2 SPD for hardwired parallel installations on 120/240 VAC Split phase circuits.

## INSTRUCTIONS:

**Caution:** Measure all voltages to insure applied voltage does not exceed the voltage rating of the unit. Improper installation voids the warranty.

This unit must be connected in parallel with the equipment to be connected.

**NOTE:** Suitable for use on a circuit capable of delivering not more than 10,000 rms symmetrical Amperes, when protected by a 20 Ampere circuit breaker rated 120 Volts minimum.

This SPD contains no serviceable parts.

1. Turn off main power before beginning the installation.
2. Remove the front cover from panel.
3. Remove the 3/4" knockout on the side of the panel box.
4. Unscrew nut from unit.
5. Feed all wires through the knockout hole then through nut. Tighten the nut to secure the unit to the panel.
6. Connect the green (Ground) wire to the ground bus.
7. Always have one common ground per system to eliminate the possibility of a differential in ground potentials.

**Ground Resistance Rule:** Max ground resistance is 25 ohms, 5 ohms or less is optimum. This cannot be an assumed value and must be measured to assure proper grounding.

8. Connect the phase (Black) wires to the load side of the main, making sure the leads are as short as possible (Ground being the shortest).
9. After all connections have been made and no hazards exist, restore power.

**NOTE:** The LED on the unit must be on, if the LED is off than surge protection is compromised and the unit must be replaced.

EXPECTED SYSTEM VOLTAGES				
Part# 89114	L1-G	L1-N	L1-L2	L2-G
DTK-120/240 CM+	120		240	120

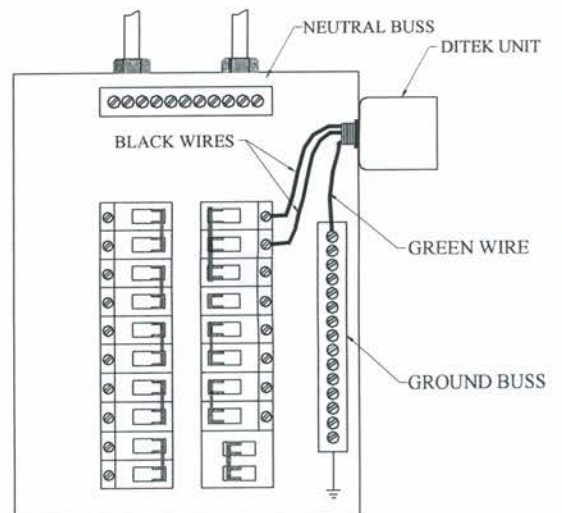

## BREAKER PANEL

DITEK Technical Support Available 24/7

1-888-472-6100

www.ditekcorp.com

Doc # INT-100105-001

Part No. 191130 Rev. 3