



Catalog Number 70020
UPC Number 60198670020
Description Ceiling pull chain with Chain
ON-OFF



Features

- Heavy Duty
- SPST
- ON-OFF
- 6" 18 AWG Leads
-
-

General

Material: Nickel Plated Chain
HD Non-Metallic Housing

Dimension Information

See Engineering Dwg

Specifications

Temperature Rating: 85°C
Voltage Rating: 125/250 VAC
Flammability Rating: N/A
Amperage Rating: 6 AMP, 125VAC
3 AMP, 250VAC

Packaging

Bag Qty 10
Bulk Qty 100 Part# 7002+A11

Certifications

UL Yes
CSA Yes
ROHS



70020

PULL CHAIN SWITCH ON/OFF

RATED 1A 125VT. 3A 125VT.
3A 250VAC.
6A 125VAC 125VL

TEMPERATURE: 85°C

NIPPLE :1/8NPS27 .531" long AVAILABLE

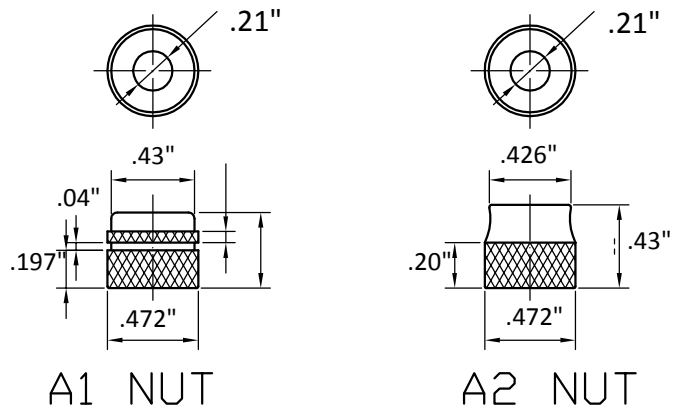
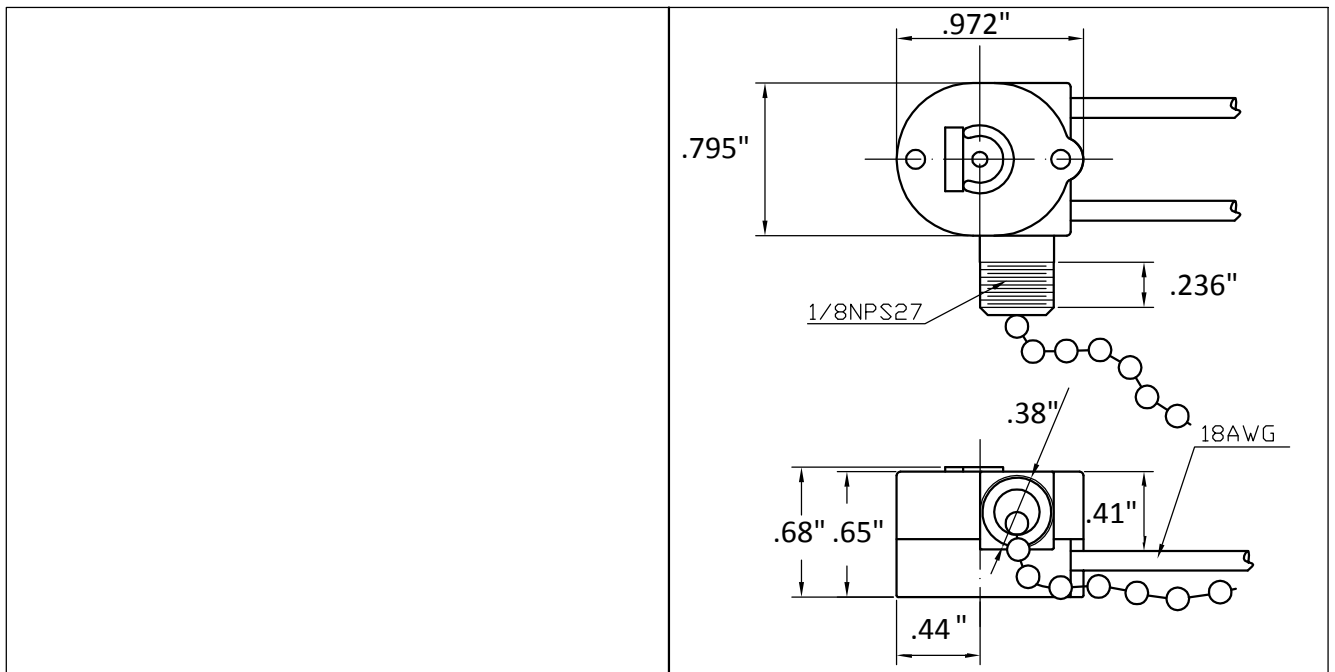

Revised 7-16-2011

A1 NUT

A2 NUT