



**Catalog Number** 11672  
**UPC Number** 60198611672  
**Description** Non-Insulated Locking Fork Spade Terminals  
 16-14 AWG



**Features**

Manufactured from high strength copper alloy  
 Electro-tin plated for corrosion resistance  
 Wire range stamped on the surface for easy interpretation  
 Brazed seam prevents splitting under maximum pressure  
 Serrated barrel provides excellent electrical contact and pull-out resistance characteristics at barrel  
 Locking tabs on Tang for increased pull-out force resistance

**General**

**Insulation Type** N/A  
**Material** Copper  
**Finish** Electro-tin plated  
**Color** N/A  
**Wire Range** 16-14 AWG  
**Stud Size** #10

**Dimension Information**

**L Inches (mm)** 0.63  
**W Inches (mm)** 0.366  
**D Inches (mm)** 0.161  
**d1 Inches (mm)** 0.091  
**d2 Inches (mm)** 0.209  
**E Inches (mm)** 0.189  
**F Inches (mm)** 0.256  
**T Inches (mm)** 0.031

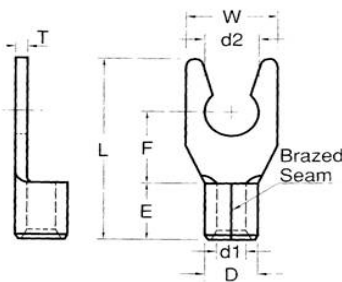

**Specifications**

**Temperature Rating** 150°C  
**Voltage Rating** 600 V  
**Flammability Rating** N/A  
**Amp Rating** 16 AWG 18 Amps  
 14 AWG 30 Amps

**Packaging**

**Bag Qty** 100  
**Master Bag Qty** 1000

**Certifications**

**UL** Yes  
**cUL** Yes  
**RoHS** Yes

Morris Products 53 Carey Road, Queensbury, NY 12804

[www.morrisproducts.com](http://www.morrisproducts.com)



REV	DESCRIPTION	DATE
△	RDK-97127	2008/07/23
△	RDK-98020	2009/08/28

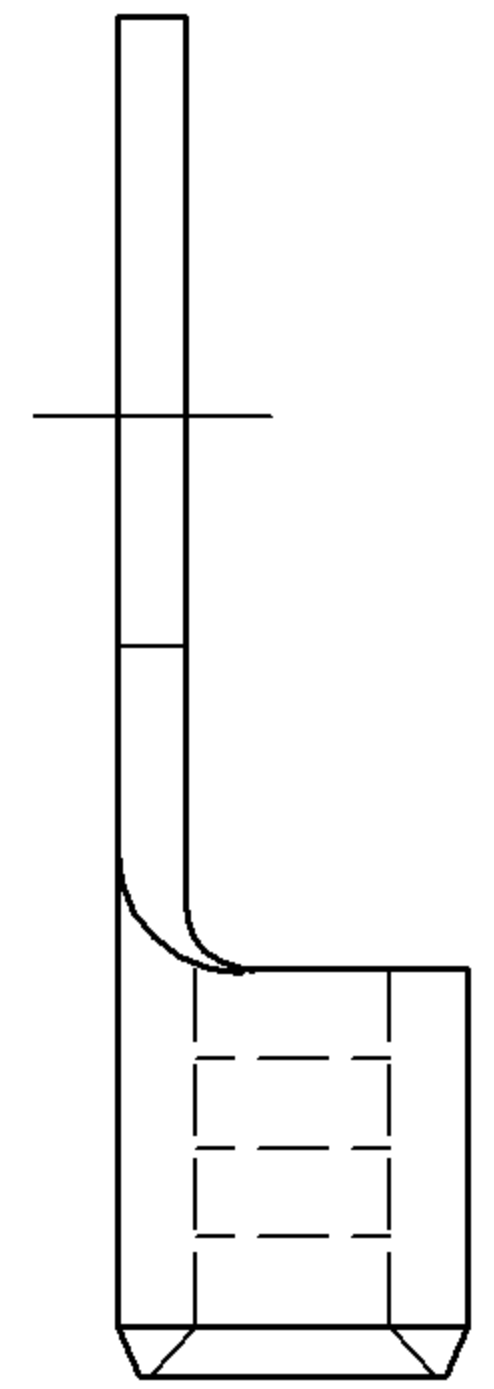
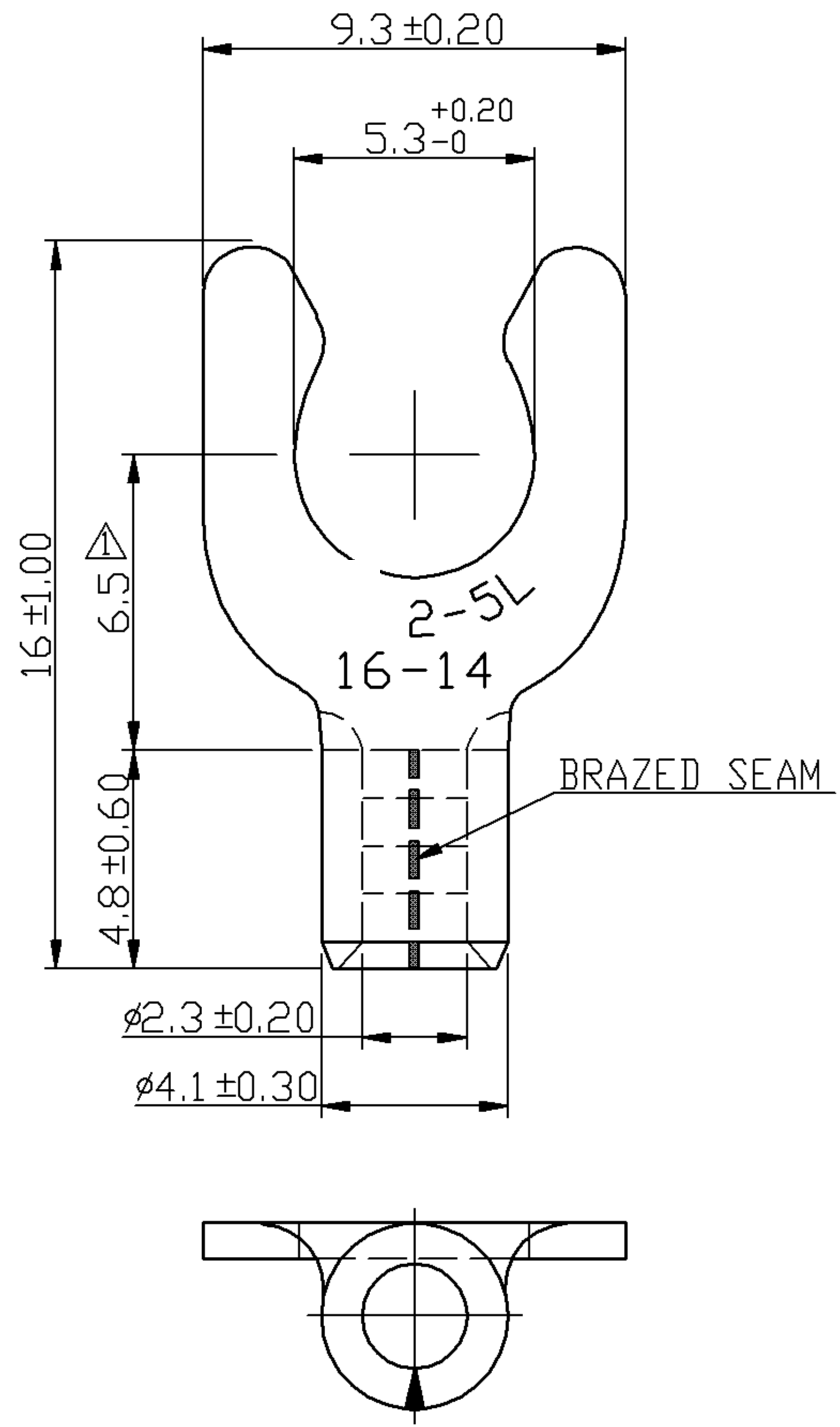

NOTE :

1. MAXIMUM ELECTRIC CURRENT : 

A.W.G.	16	14		
AMP.	18	30		
2. WIRE RANGE : 16-14 A.W.G. ( 1.5-2.5 mm<sup>2</sup> )
3. SURFACE TREATMENT : TIN PLATED
4. THICKNESS : 0.80 mm

△ Tolerance Unless	
□ Otherwise Specified	
0 >	mm ±
>	mm ±
>	mm ±
>	mm ±
	ANGLE
	0° > ° REF ±
	° > ° ±
	° > ° ±

NAME	NON-INSULATED LOCKING SPADE TERMINALS			UNIT	mm	
PART NO.	11672	MATERIAL	COPPER	APPROVE		
NUMBER		SCALE	SHEET	PAGE	CHECKED	
DATE	2006/04/11	4/1	1-2	10F2	DRAWN	

Morris Products Inc.  
53 Carey Rd. Queensbury, NY 12804