

ENFORCER®

Self-Contained Siren or Siren/Strobe Manual



SH-816S-SQ/R shown

SH-816S-BQ	Siren
SH-816S-SQ/x*	Siren/Strobe

*Replace "x" with the first letter of the lens color, amber, clear, blue, red.

Features:

- 9~15 VDC
 - Low current draw
 - 120dB Warble-tone siren
 - 25W Speaker for audio or broadcast system input (broadcast will interrupt the siren)
 - Built-in tamper alarm output
 - Weatherproof for outdoor/indoor use, IP65
 - Easy installation
 - Mount directly to wall or to most common back boxes
- In addition to the above, SH-816S-SQ adds:**
- Bright xenon tube strobe light
 - Strobe can be triggered separate from siren
 - Strobe available in amber, clear, blue, or red

ENFORCER Self-Contained Siren or Siren/Strobe

Introduction:

The ENFORCER Siren/Strobes are multi-purpose devices: siren, speaker, and optional strobe (SH-816S-SQ only). It can serve as a regular siren, but also has an audio input that can be used to play audio or broadcast messages. Audio input will override the siren for the duration of the broadcast. The SH-816S-SQ series also includes a strobe light with a choice of amber, blue, clear, or red lenses and can be either surface mounted or installed to a standard single gang, double gang or C-type back box.

Parts List:

1x Siren unit	4x Mounting screws	4x Plastic wall anchors
1x Back removal tool	1x Manual	

Specifications:

Model	SH-816S-BQ	SH-816S-SQ
Type	Siren	Siren/Strobe
Operating voltage	9~15 VDC	
Current draw (max.)	Strobe	190mA@12VDC
	Siren	680mA@12VDC
	Both	870mA@12VDC
Siren volume	120dB	
Speaker rating	25W Peak	
Strobe flash rate	N/A	75 per minute
Tamper output	100mA@30 VAC/VDC	
IP Rating	IP65	
Operating humidity	0~95%	
Operating temperature	-4°~131° F (-20°~55° C)	
Housing material	White polycarbonate plastic	
Dimensions	6 ¹ / ₈ "x4 ¹⁵ / ₁₆ "x4 ¹ / ₂ " (155x126x115 mm)	6 ¹ / ₈ "x7"x4 ¹ / ₂ " (155x178x115 mm)
Weight	1-lb 13-oz (812g)	2-lb 2-oz (957g)

Overview:

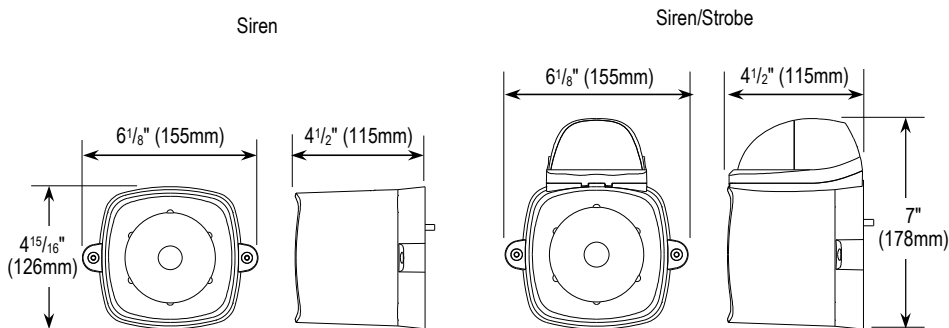

Installation:

1. Determine the desired location and installation—surface or to a back box.
2. Remove the two screws from the two tabs that attach the back to the main unit (See Fig. 1).
3. Squeeze the included back removal tool and insert through the wiring access hole in the back of the unit. Release and pull carefully until the back is removed from the unit.
4. Thread the wires (up to 8 wires, depending on installation, see "Sample Applications" on pg. 4) through the center hole in the back and install the back to the wall/back box using the four mounting holes in the back oriented so that the engraved arrow is pointing up. Be careful not to use the hole for the tamper switch (see Fig. 2).

NOTE: For non-standard boxes, drill out any other holes engraved in the oval indentations on the back as needed.

5. Connect the wires for the desired installation to the terminals as shown in Fig. 3 and referring to the sample applications on pg. 4. Note that audio input requires power to the P.A. (+) terminal.
6. Carefully slide the main unit onto the back, ensuring the correct orientation (note the notch and the arrows) and that the terminal plugs are correctly engaged (see Fig. 1).
7. Attach the main unit to the back using the two screws removed in step 2.

Fig. 1

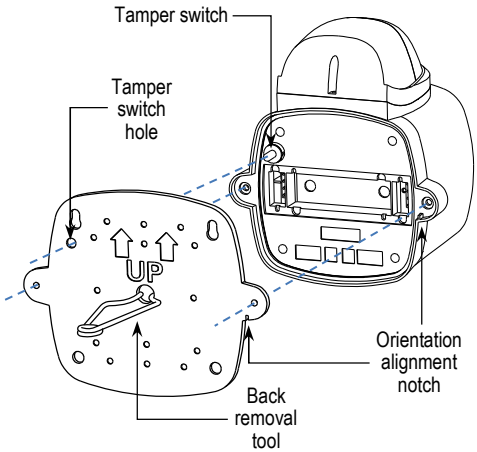

Fig. 2

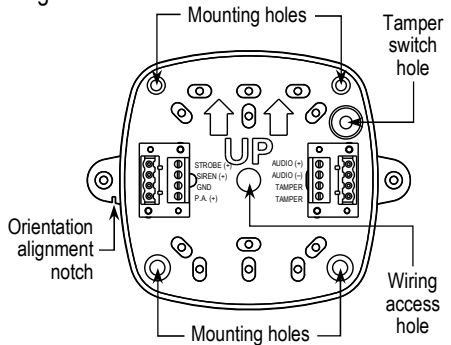
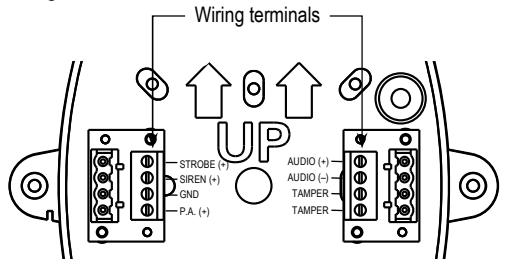

Fig. 3



ENFORCER Self-Contained Siren or Siren/Strobe

Sample Applications:

Triggering both siren and strobe* together
(also showing audio input)

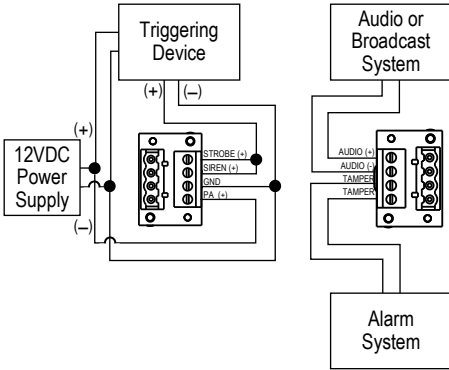

Siren and strobe* triggered by separate devices
(also showing audio input)

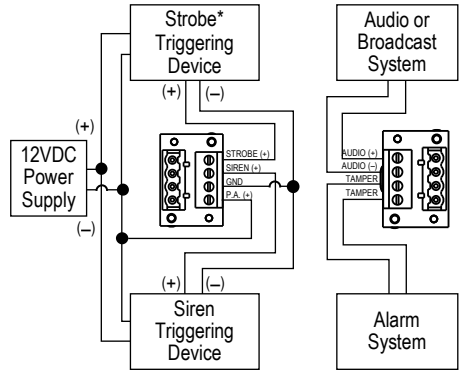

*Strobe available on SH-816S-SQ only

NOTE: The audio broadcast will override and interrupt the siren for the duration of the broadcast.

IMPORTANT: Users and installers of this product are responsible for ensuring this product complies with all national, state, and local laws and statutes related to monitoring and recording audio and video signals. SECO-LARM will not be held responsible for the use of this product in violation of any current laws or statutes.

WARRANTY: This SECO-LARM product is warranted against defects in material and workmanship while used in normal service for one (1) year from the date of sale to the original customer. SECO-LARM's obligation is limited to the repair or replacement of any defective part if the unit is returned, transportation prepaid, to SECO-LARM. This Warranty is void if damage is caused by or attributed to acts of God, physical or electrical misuse or abuse, neglect, repair or alteration, improper or abnormal usage, or faulty installation, or if for any other reason SECO-LARM determines that such equipment is not operating properly as a result of causes other than defects in material and workmanship. The sole obligation of SECO-LARM and the purchaser's exclusive remedy, shall be limited to the replacement or repair only, at SECO-LARM's option. In no event shall SECO-LARM be liable for any special, collateral, incidental, or consequential personal or property damage of any kind to the purchaser or anyone else.

NOTICE: The SECO-LARM policy is one of continual development and improvement. For that reason, SECO-LARM reserves the right to change specifications without notice. SECO-LARM is also not responsible for misprints. All trademarks are the property of SECO-LARM U.S.A., Inc. or their respective owners. Copyright © 2020 SECO-LARM U.S.A., Inc. All rights reserved.

SECO-LARM® U.S.A., Inc.

16842 Millikan Avenue, Irvine, CA 92606
Phone: (949) 261-2999 | (800) 662-0800

Website: www.seco-larm.com
Email: sales@seco-larm.com

 PICAN4

MI_SH-816S-xQ_200609.docx