

# TECH-SPEC:

## Product Reference Sheet

### 216\_V

Example: **216 | A | V | 36**  
 Profile# Finish Vinyl Length

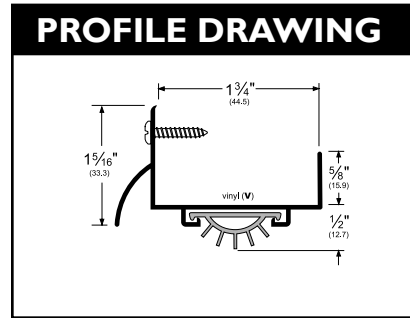

**CATEGORY:** Door Bottom

**TYPE:** Door Bottom

**FINISHES:** A (Mill Finish), BDG (Bright Dip Gold Anodized), D (Dark Anodized), G (Gold Anodized), PW (Painted White), SN (Satin Nickel Anodized)

**LENGTHS:** Up to 185"

**WIDTH:** 1-5/16" (33.33 mm)

**HEIGHT:** Overall: 1-9/16" (39.69 mm), Underneath door: 1/2" (12.7 mm)

**WEIGHT:** Estimated per foot: 0.4 lbs

**RATINGS:**   

**PRODUCT APPROVALS:**

- 216\_V\_ has been tested and approved under UL10C for Fire and UL1784 for Smoke.
- Category J and H gaskets for use with classified steel covered composite, hollow metal doors rated up to and including 3 hours; wood and plastic covered composite doors rated up to and including 1-1/2 hours; and wood core doors rated for 20 minutes without hose stream.

**LEAD TIME:** 4 working days (or less)

**AVAILABLE:** Shipped from PEMKO's Memphis, Ventura, Vancouver, and Toronto locations

**CROSS REFERENCE:** CR Laurence: DB003AV; DraftSeal: DS216; Hager: 778S, 778V; NGP: 36EV, 119N, 319EV, 319V; Reese: DB595

**INSTRUCTIONS:** Available upon request and on website

**CAD DRAWINGS:** Available upon request and on website

**PROFILE DRAWINGS:** Available upon request and on website

**CUT SHEET:** Available upon request and on website

[www.pemko.com](http://www.pemko.com)

Memphis, TN USA  
 P.O. Box 18966  
 Memphis, TN 3818  
 P: 800.824.3018  
 F: 800.243.3656

Ventura, CA USA  
 P.O. Box 3780  
 Ventura, CA 93006  
 P: 800.283.9988  
 F: 800.283.4050

Vancouver, BC Canada  
 103-2480 Mt. Lehman Rd.  
 Abbotsford, BC V2T 6W3  
 P: 877.535.7888  
 F: 877.535.7444

Toronto, ON Canada  
 160 Four Valley Dr.  
 Vaughan, ON L4K 4T9  
 P: 877.535.7888  
 F: 877.535.7444