

ARTICLE NUMBER	FINISH
429.99.363	BLACK
429.99.763	WHITE

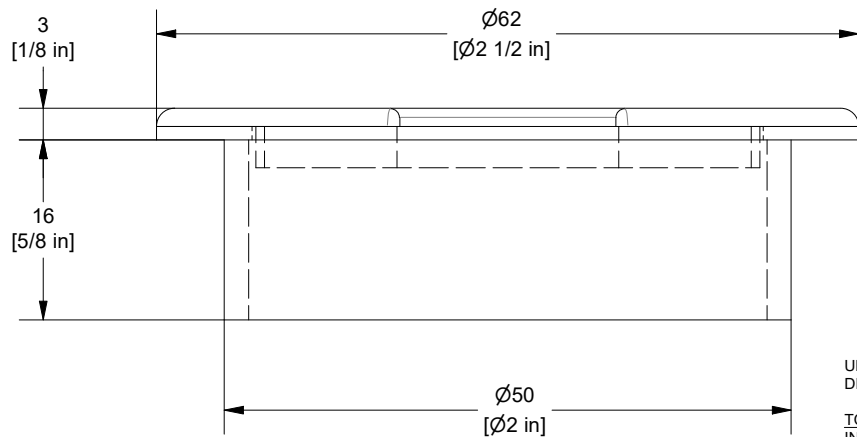
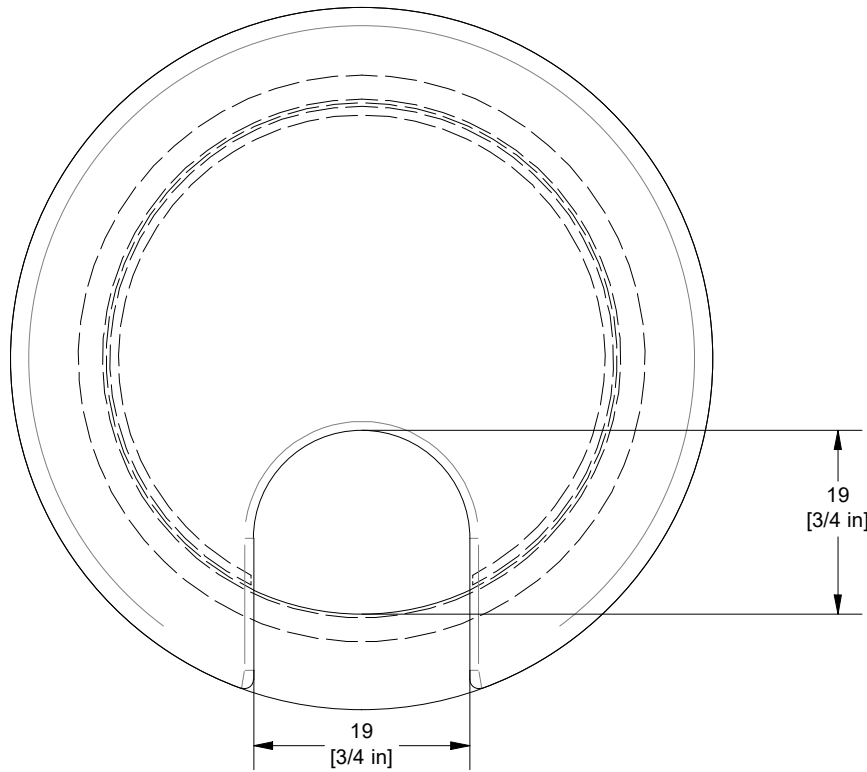

UNLESS OTHERWISE SPECIFIED
DIMENSIONS ARE IN MM(IN)

TOLERANCES:	
INCHES:	MILLIMETERS:
.X: ±0.1	.X: ±3
.XX ±0.03	X.X: ±0.8
.XXX ±0.015	XX.X: ±0.38

ANGULAR
MACHINE: ±0.5°, BEND: ±1.0°

GEOMETRIC TOLERANCES PER
ASME-Y14.5-94

REVISION

ITEM/CATALOG NUMBER 429.99.X23	DRAWING NUMBER 429.99.X63
TITLE GROMMET-2"	
MATERIAL HIPS	FINISH SEE NOTES
<small>NOTICE</small> <small>THIS DRAWING AND ALL INFORMATION THEREON IS THE PROPERTY OF HÄFELE AMERICA, INC. IT IS SUBJECT TO CHANGE WITHOUT NOTICE.</small>	
DRAWN BY: BB/NPG	
APPROVED BY: SH	
DATE: 7/30/2023	
SCALE: 3 : 2	
TOLERANCE SPECIFICATION SEE NOTES	<small>ISO E</small> 
SIZE A	SHEET 1 OF 1