

Instructions for use
—Type 2 Fix

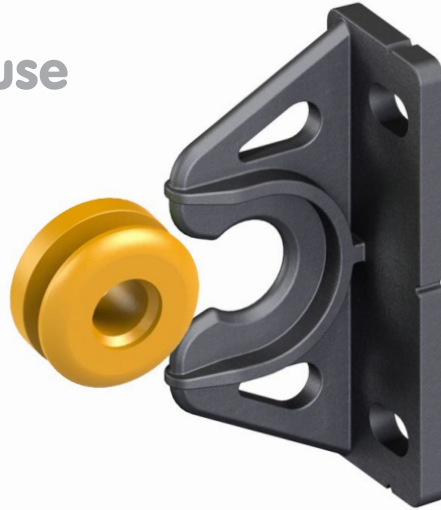

Type 2 button-fix

The Button-fix concept is simple: durable nylon Buttons are attached to the background structure and the mating Fixes are attached to the removable panel. Push firmly on the panel until the Button-fixes ‘click’.

The Type 2 Button-fix connects panels at 90° and engages with a straight push. It is ideal for panels with no clearance above or at the side and applications where the emphasis is on ease of access.

Visit the website for more information on the complete Button-fix range, including videos of the Type 2 Button-fix in use. You can also obtain a new copy of these instructions from the website in the event of loss or in the event that Buttonfix modifies the instructions.

Buttonfix Limited retains the right to modify the instructions as it deems appropriate and the consumer is responsible for checking the website for the latest information.

Warnings

—Button-fix is intended for furniture construction and interior fittings and is not intended, nor should it be used, for any other purpose.

—**WARNING:** Serious damage to property and severe bodily injury can result from (1) improper use, application or installation of the Button-fix or (2) use as part of improperly designed or constructed assemblies or materials.

—Provided that the screws and substrate are properly matched, and all other instructions complied with, tests showed that a vertical panel under no other loading than its own weight, fixed with four Type 2 Fixes, can

weigh up to a maximum of 175lbs. Other configurations should always be properly tested by the user to their satisfaction.

—Each Type 2 Fix requires approximately 30lbs of force to separate the Button and Fix; this should be taken into account when designing your installation and defining your safety factors.

—**CAUTION:** Type 2 Fixes should only be used on vertical panels or in applications where the weight of the panel does not act to separate the fixing. In critical applications, always use the Safety Cord accessory.

—Avoid any contact with aggressive solvents and cleaning products.

—It is not possible for Buttonfix to warn the consumer about every possible danger related to use of the Button-fix and the consumer must use his or her own good judgment when installing and using the Button-fix.

The button

There are two Buttons to suit different screw types. These are colour-coded lime green for #10 flat head wood screws, or orange for Ø6.2mm Varianta Euro screws (to fit Ø5mm pilot holes).

Check with your panel supplier which screw type is best for your application.

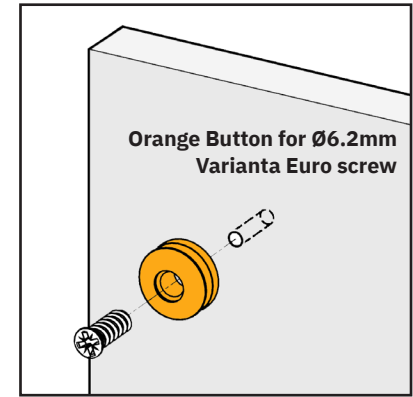
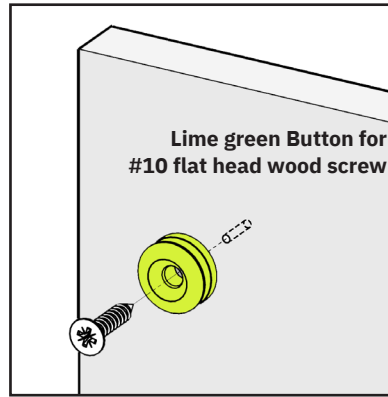

Safety Cord accessory

In situations where safety is an issue, install two Safety Cords, one to each Fix in the top corners.

An additional Button is used to capture the loop on the Safety Cord, installed adjacent to the fixing Button. To remove the panel completely, ease the loop on the Safety Cord off the Button.

Please note that the Safety Cord accessory needs to be ordered separately from the Button-fixes.

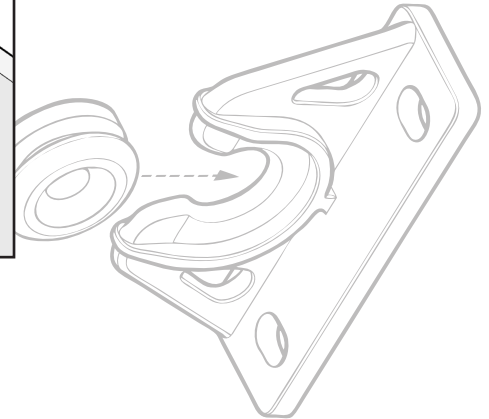
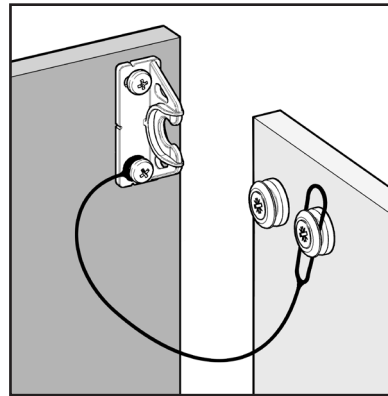

Installation

The Type 2 Fix can be mounted to suit an overflying panel or internal panel arrangement.

1. Overflying panel

The Type 2 Fix is attached to the removable panel as shown in the diagrams on the right, with fixing centres measured 0.51" in from the surface onto which the Button is fixed.

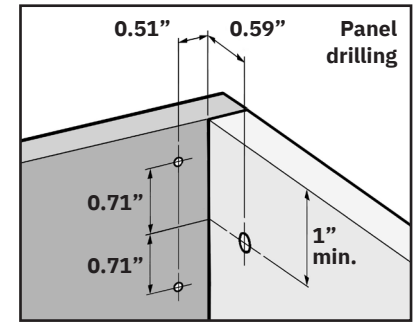
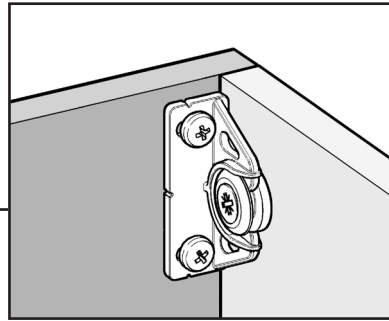

2. Internal panel

The Type 2 Fix is attached to the removable panel as shown in the diagrams on the right, with fixing centres measured 0.47" in from the edge of the panel, giving a 0.04" clearance between the panel and the surface onto which the Button is fixed.

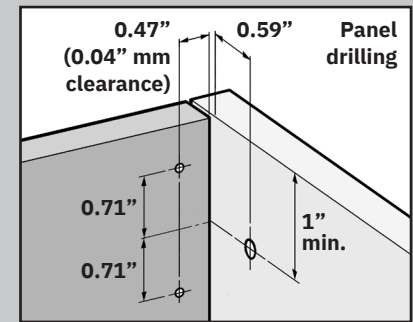
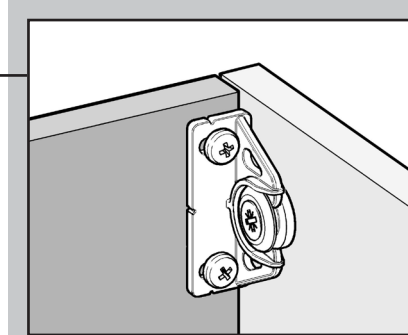

A useful tip

The holes for mounting the Fix are slotted to allow a small degree of adjustment.

First, tighten the fixing screws gently, such that the Fix can move with some resistance. The panel may then be installed, positioned and removed, before finally tightening the screws fully – this facilitates precise alignment of the panel.

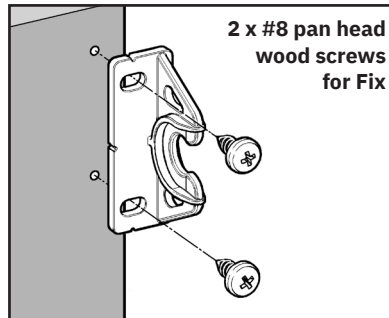

Fix marker accessory

The Fix marker accessory aids swift panel mounting, reducing the need for measuring and marking out.

1. Overflying panel

The marker and Button-fix are assembled as shown in diagram A and used to mark the Button position (B).

After fixing the Button, the removeable panel is then pushed firmly against the marker spikes, giving an accurate position for the Fix (C).

2. Internal panel

The marker can also be used for internally mounted panels, but must be assembled as shown (D).

The Button is marked out and fixed at the required position (this will depend on the panel thickness), before installing the marker tool and pushing the panel firmly against the marker spikes (E).

Tip: use some adhesive tape to stop the assembly rotating on the Button.

Please note that the Fix marker accessory needs to be ordered separately from the Button-fixes.

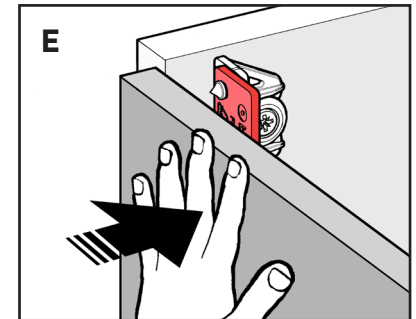
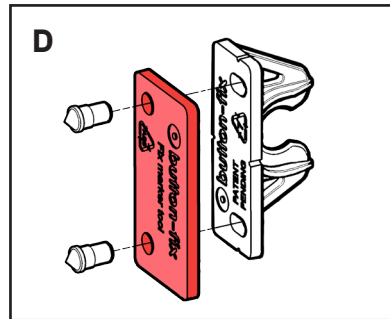
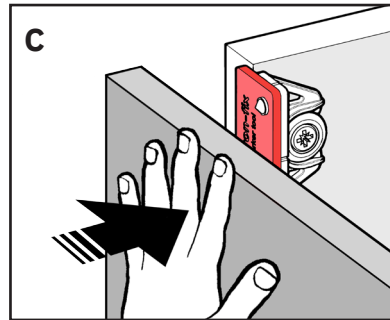
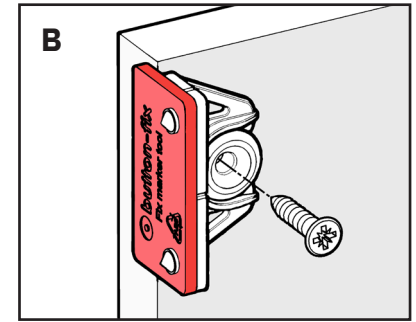
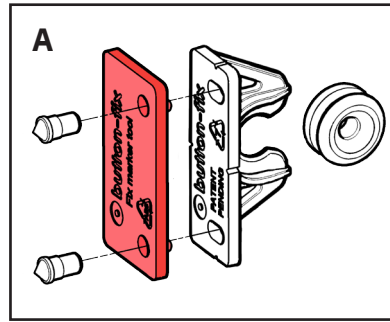

A simple hinge

When a Type 2 Fix is used to hold an internal panel, the panel may rotate about two Fixes provided that there is sufficient clearance around the panel.

In this way, the Type 2 Fix can be used to create simple pivoted access panels.

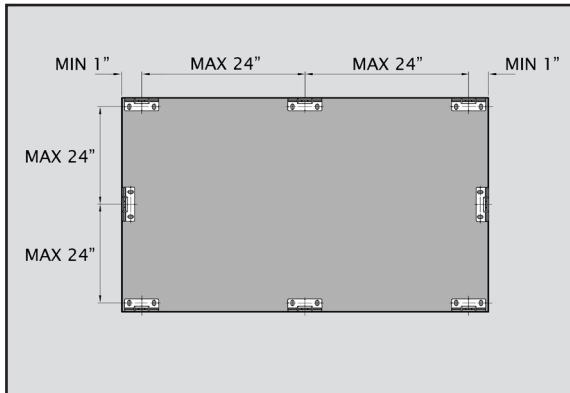
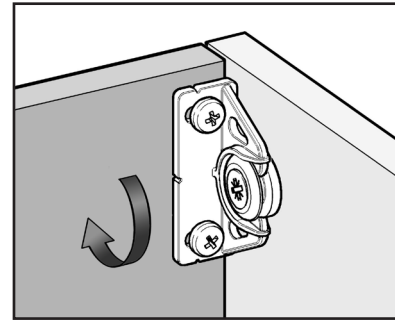

Suggested layout

As an approximate guide, we suggest that Type 2 Fixes are spaced no greater than 24" apart. This may vary, dependent upon the mass and stiffness of the panel.

The Type 2 Fixes may be installed in a vertical or horizontal orientation, or a combination of both (as shown).

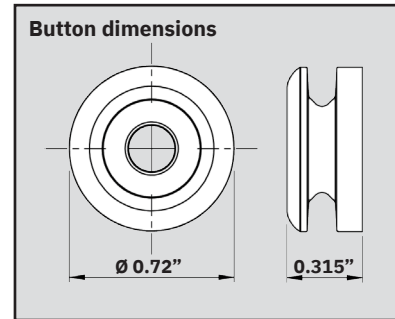
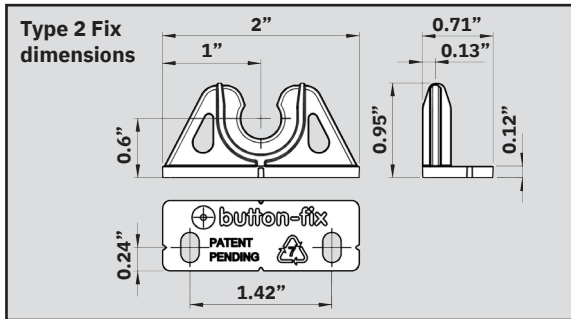

Manufactured in the UK

**Buttonfix Limited
Unit A, 1 Britton Street
London, EC1M 5NW**

T: +44 (0)20 8150 7190

E: info@button-fix.com



button-fix.com