

# Montageanleitung Mounting instructions Instructions de montage



Hilfe: [eku.ch/planungshilfen](http://eku.ch/planungshilfen)  
 Help: [eku.ch/planningtools](http://eku.ch/planningtools)  
 Aider: [eku.ch/aidesalaplannification](http://eku.ch/aidesalaplannification)

15 - 18

Video

**EKU FRONTINO® 20 H (FS)**



Schweizer Qualität - getestet nach EN 15706  
 Swiss Quality - tested in accordance with EN 15706  
 Qualité suisse - testée selon EN 15706

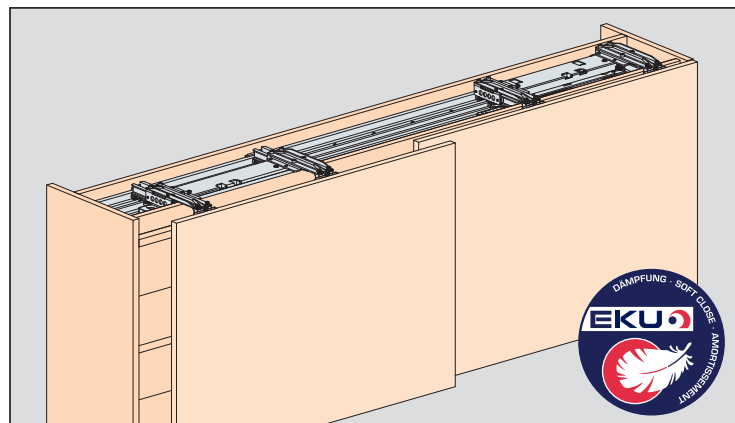

2 Türen Doors Portes	Typ S = KAM 1200-1799 mm No. 053.3283.081	Typ M = KAM 1800-2199 mm No. 053.3283.082	Typ L = KAM 2200-2400 mm No. 053.3283.083
	1x		1x
	1x		1x
	2x		1x
	1x		1x
	1x		1x
	1x		2x
	1x		1x
	1x		4x

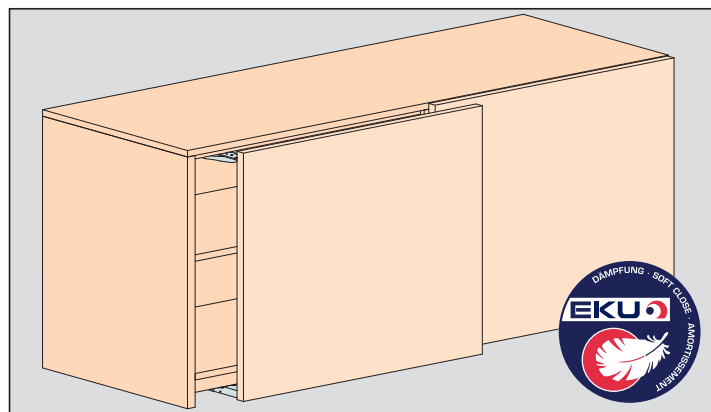

2 Türen Doors Portes	Typ S = KAM 1200-1799 mm No. 053.3283.081	Typ M = KAM 1800-2199 mm No. 053.3283.082	Typ L = KAM 2200-2400 mm No. 053.3283.083
	1x		1x
	1x		1x
	2x		1x
	1x		1x
	1x		1x
	1x		2x
	1x		1x
	1x		4x

2 Türen Doors Portes	No. 053.3284.071		
	1x		1x
	1x		1x



EKU AG Schiebelösungen, Wilerstrasse 90, 8370 Simnach, Switzerland, Tel. +41 (0)71 96 96 100  
 Fax +41 (0)71 96 96 110, [office@eku.ch](mailto:office@eku.ch), [www.eku.ch](http://www.eku.ch) Certified ISO 9001 - Member of the HAWA Group

# Montageanleitung Mounting instructions Instructions de montage



Hilfe: [eku.ch/planungshilfen](http://eku.ch/planungshilfen)  
 Help: [eku.ch/planningtools](http://eku.ch/planningtools)  
 Aider: [eku.ch/aidesalaplannification](http://eku.ch/aidesalaplannification)

15 - 18

Video

**EKU FRONTINO® 20 H (FS)**



Schweizer Qualität - getestet nach EN 15706  
 Swiss Quality - tested in accordance with EN 15706  
 Qualité suisse - testée selon EN 15706

## Garnituren/Sets/Garnitures

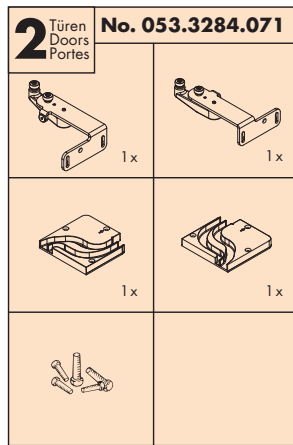
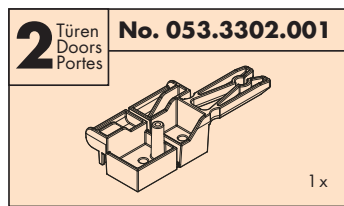
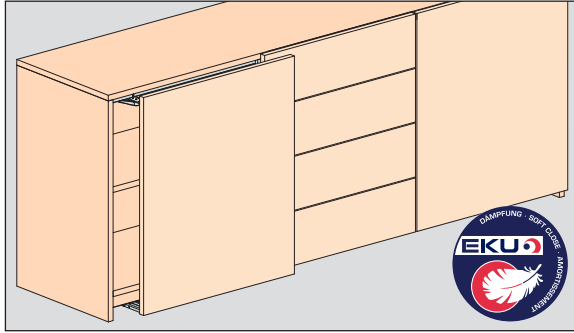

<b>2</b> Türen Doors Portes	<b>Typ S = KAM 1200-1799 mm</b>	<b>No. 053.3283.081</b>
	<b>Typ M = KAM 1800-2199 mm</b>	<b>No. 053.3283.082</b>
	<b>Typ L = KAM 2200-2400 mm</b>	<b>No. 053.3283.083</b>
		1 x
		1 x
		1 x
		1 x
		2 x
		1 x
		1 x
		1 x
		2 x
		1 x
		1 x
		4 x
		1 x
		1 x
		1 x
		1 x

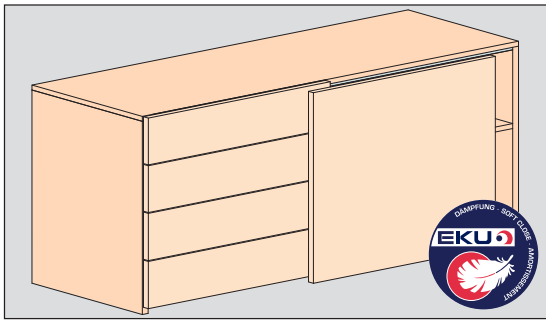

## Garnitur/Set/Garniture

<b>1</b> Türe Door Porte	<b>Typ S = KAM 1200-1799 mm</b>	<b>links</b>	<b>No. 053.3283.075</b>	<b>rechts</b>	<b>No. 053.3283.074</b>
	<b>Typ M = KAM 1800-2199 mm</b>	<b>left</b>	<b>No. 053.3283.077</b>	<b>right</b>	<b>No. 053.3283.076</b>
	<b>Typ L = KAM 2200-2400 mm</b>	<b>à gauche</b>	<b>No. 053.3283.079</b>	<b>à droite</b>	<b>No. 053.3283.078</b>
			1 x		1 x
			1 x		1 x
			1 x		1 x
			1 x		1 x
			2 x		1 x
			1 x		1 x
			1 x		1 x
			1 x		1 x
			1 x		1 x

**Abbildung: System eintürig rechts**  
 Image: System single door right  
 Image: Système une port a droite



EKU AG Schiebelösungen, Wilerstrasse 90, 8370 Simnach, Switzerland, Tel. +41 (0)71 96 96 100  
 Fax +41 (0)71 96 96 110, office@eku.ch, www.eku.ch Certified ISO 9001 - Member of the HAWA Group



Hilfe: [eku.ch/planungshilfen](http://eku.ch/planungshilfen)

Help: [eku.ch/planningtools](http://eku.ch/planningtools)

Aider: [eku.ch/aidesalaplaniation](http://eku.ch/aidesalaplaniation)



15 - 18

Video

**2-türig** | 2-doors | 2-portes

TYP: S;M;L

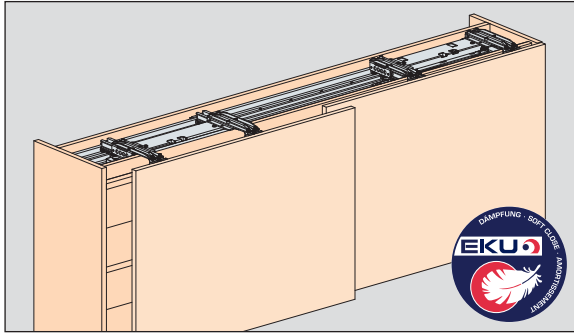

**obenlaufend** | top running | à roulement en haut

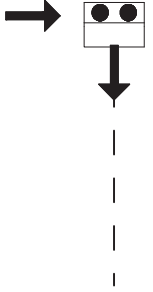

**2-türig** | 2-doors | 2-portes

TYP: S;M;L

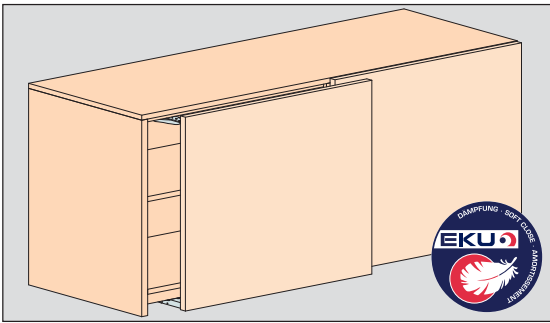

**untenlaufend** | bottom running | à roulement en bas



**Mittelteil** | Centre piece | Pièce médiane

TYP: S ~~M;L~~

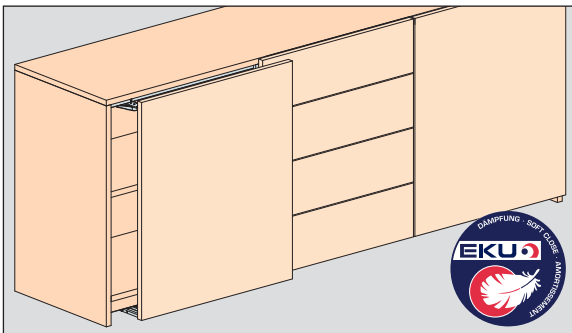

**untenlaufend** | bottom running | à roulement en bas



**Eintürig** | Single door | À une porte

TYP: S;M;L

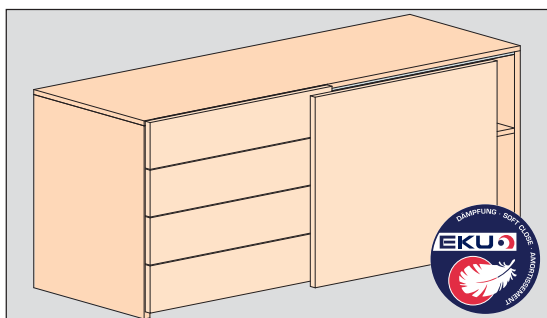

**untenlaufend** | bottom running | à roulement en bas

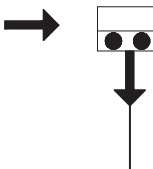

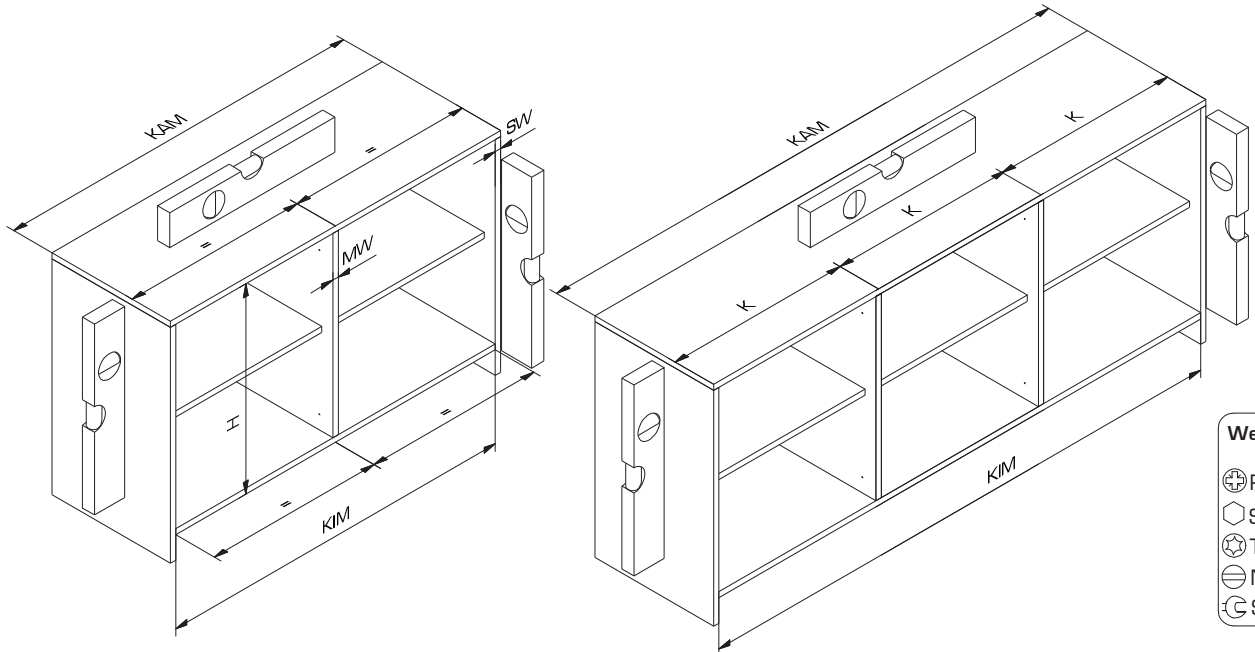

- Werkzeug | Tool | Outil**
- ⊕ PZ: 2
  - ⬡ SW: 3 / 4 / 5
  - ⊗ TX: 25
  - ⊖ No.:
  - ⊙ SW: 8

**A Schienen-Set / Track set / Set de rails**  
 Typ S: Art.No. 053.3285.182 = 1800mm  
 Typ M: Art.No. 053.3285.222 = 2200mm  
 Typ L: Art.No. 053.3285.242 = 2400mm



**Hilfe: eku.ch/planungshilfen**  
 Help: eku.ch/planningtools  
 Aider: eku.ch/aidesalaplannification



Typ S: Art.No. 053.3285.181 = 1800mm  
 Typ M: Art.No. 053.3285.221 = 2200mm  
 Typ L: Art.No. 053.3285.241 = 2400mm



Typ S: Art.No. 053.3261.180 = 1800mm  
 Typ M: Art.No. 053.3261.220 = 2200mm  
 Typ L: Art.No. 053.3261.240 = 2400mm

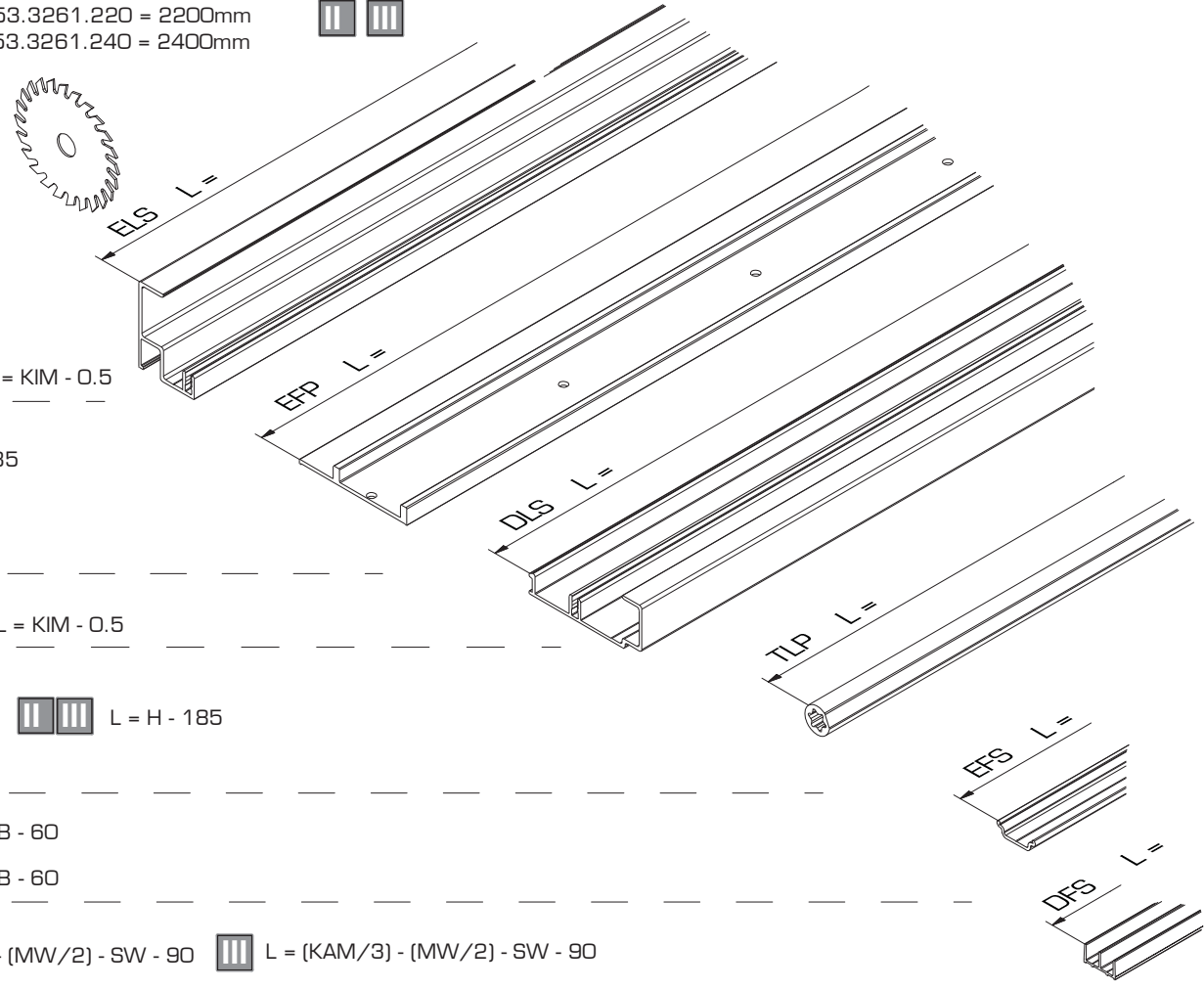
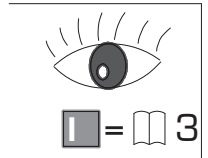

1x I II III IV L = KIM - 0.5

1x I II L = 2\*Z+35

2x III L = M+Z

1x IV L = M+Z

1x I II III IV L = KIM - 0.5

2x I L = H - 146 II III L = H - 185

1x IV L = H - 185

4x I II III L = TB - 60

2x IV L = TB - 60

2x II L = (KAM/2) - (MW/2) - SW - 90 III L = (KAM/3) - (MW/2) - SW - 90

1x IV L = (KAM/2) - (MW/2) - SW - 90

**B**

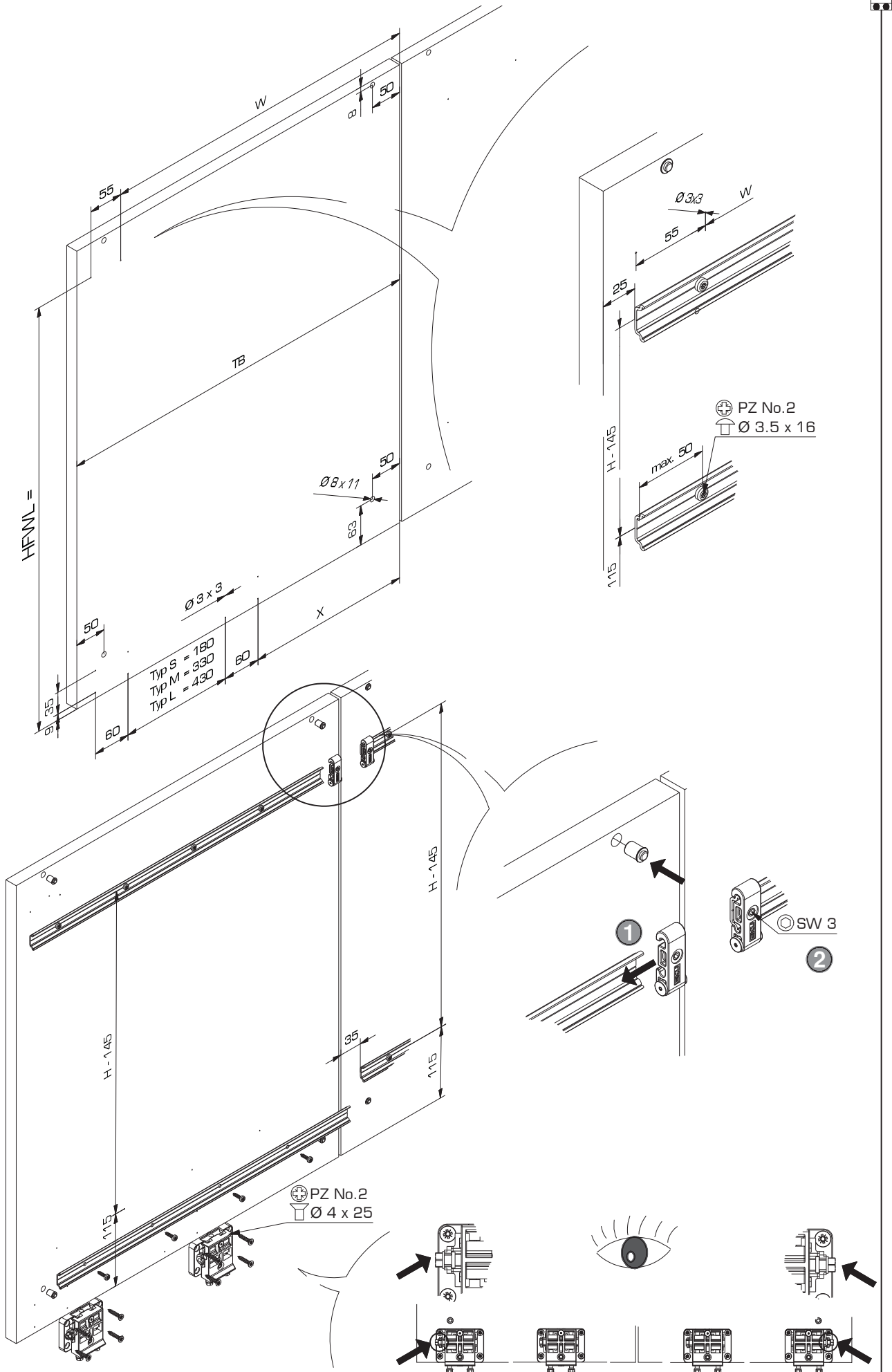
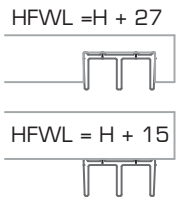

**C**

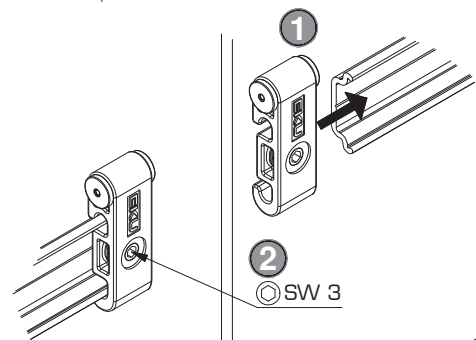
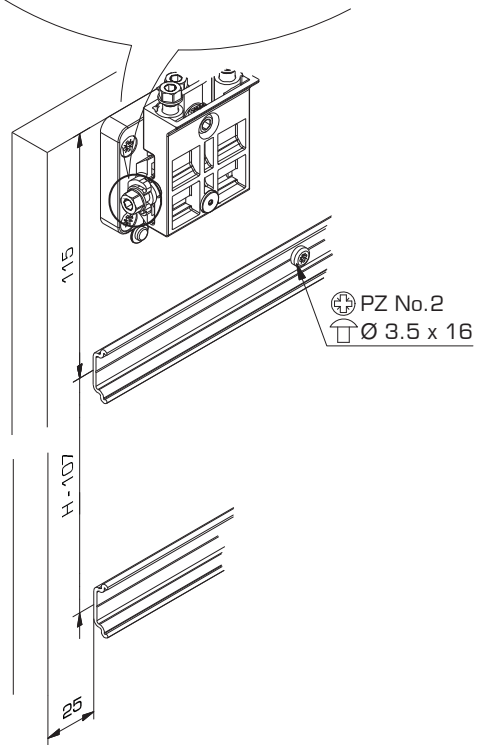
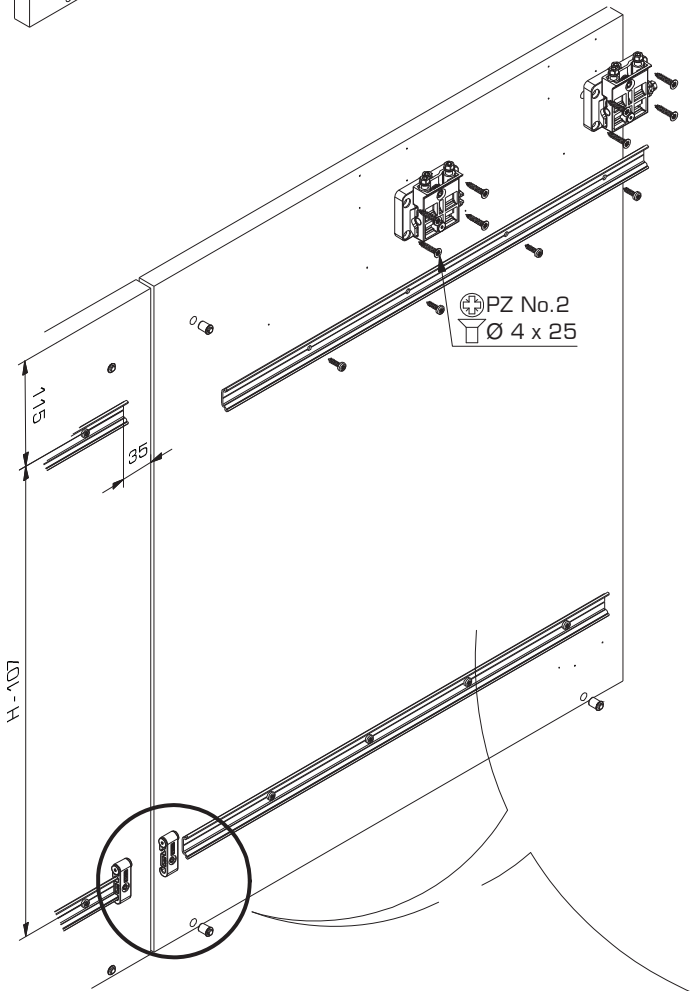
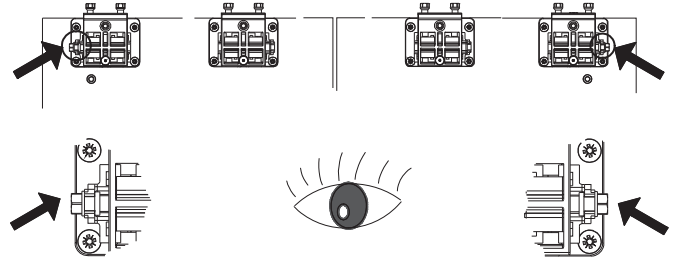
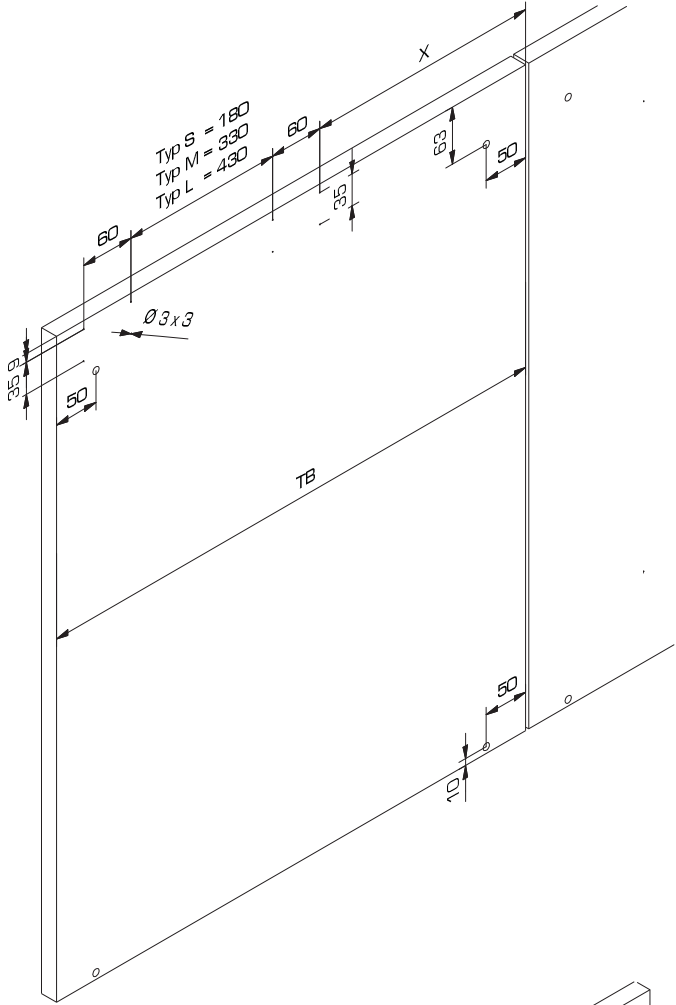

**D**

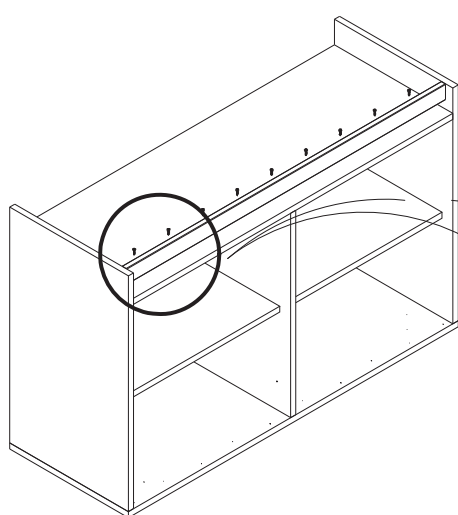
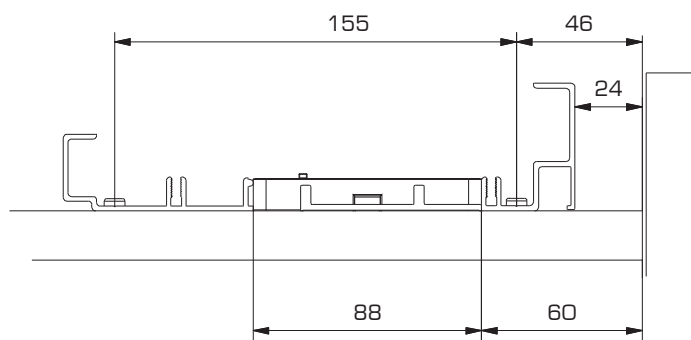

**1**

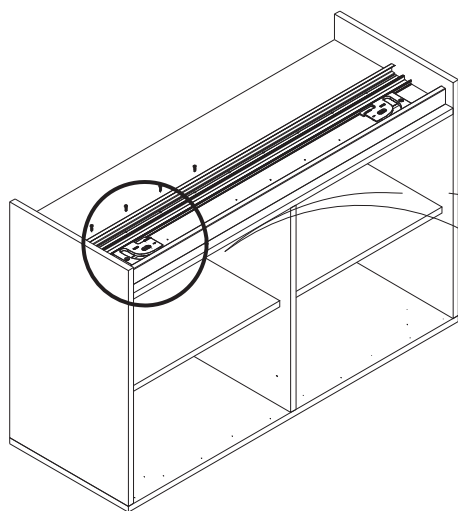
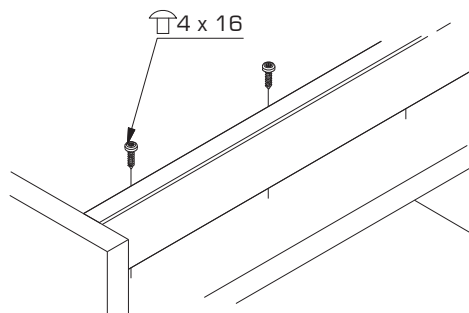

**2**

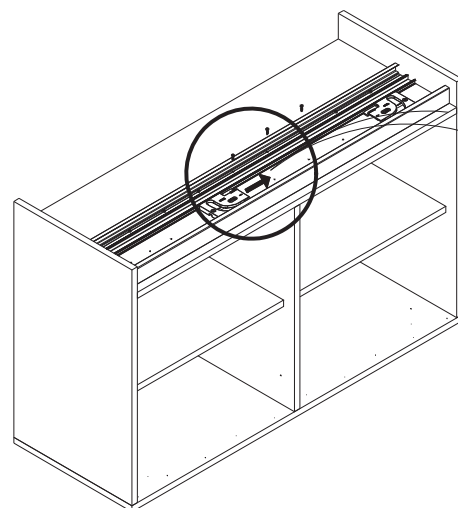
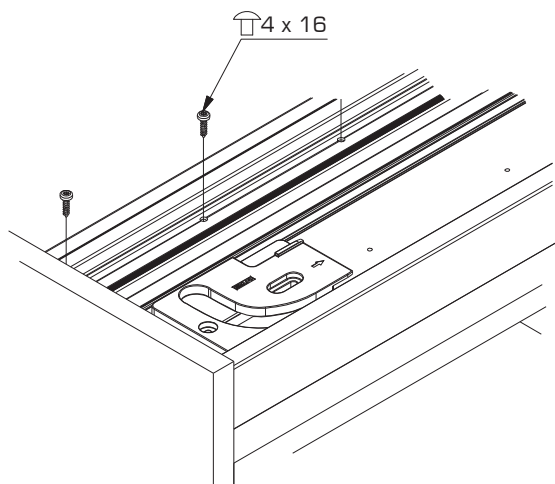

**3**

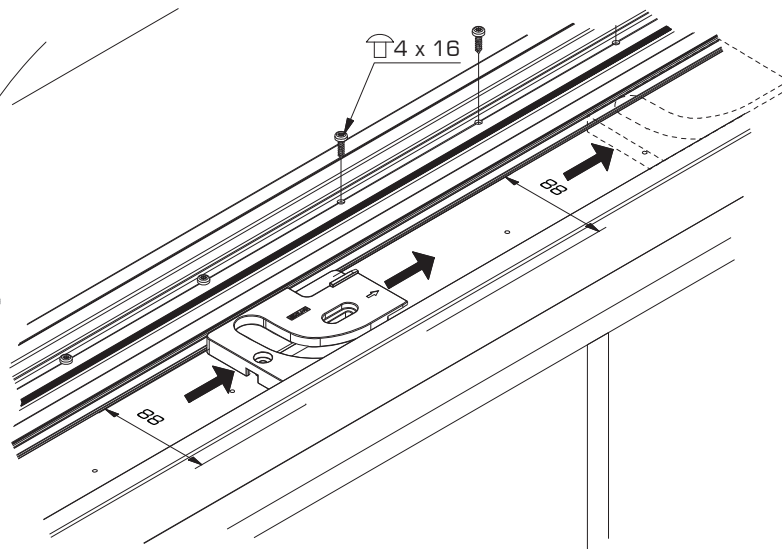



**E**

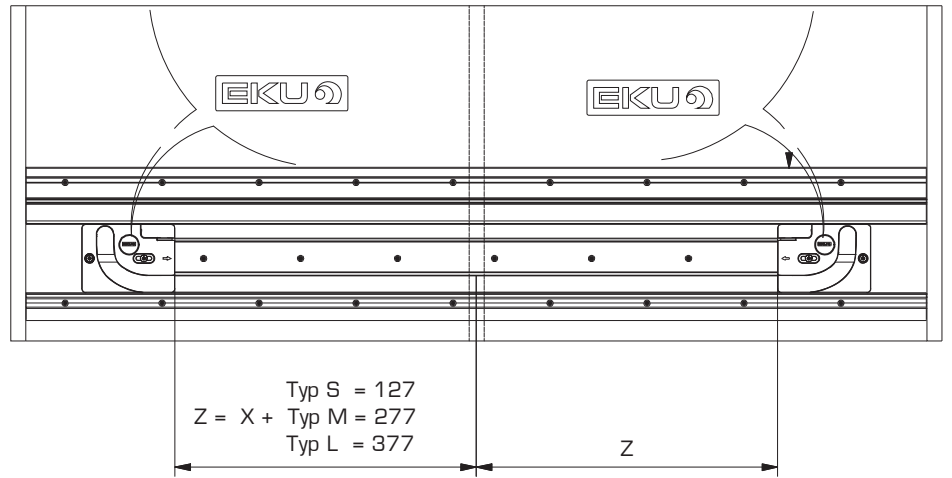
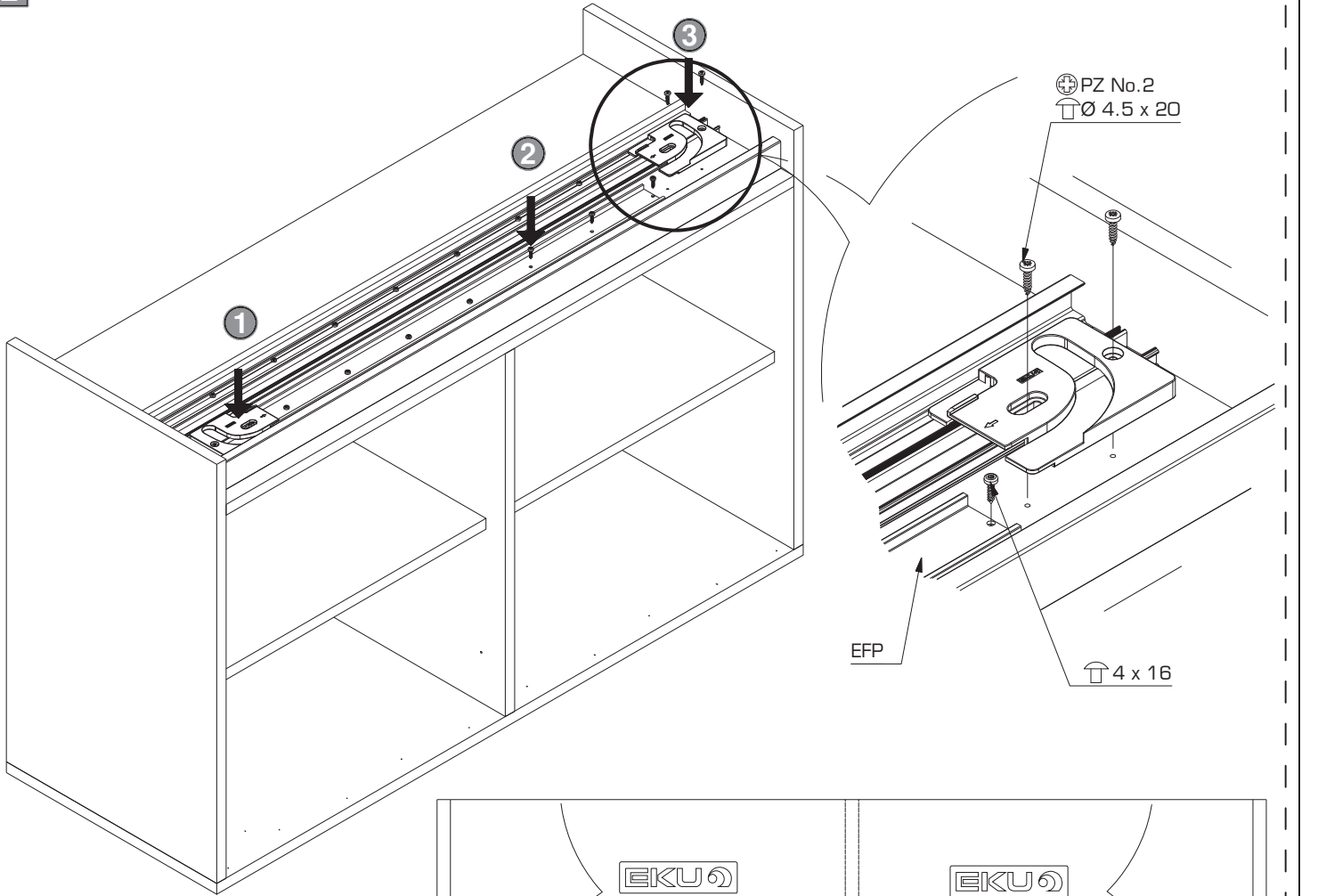

**F III IV**

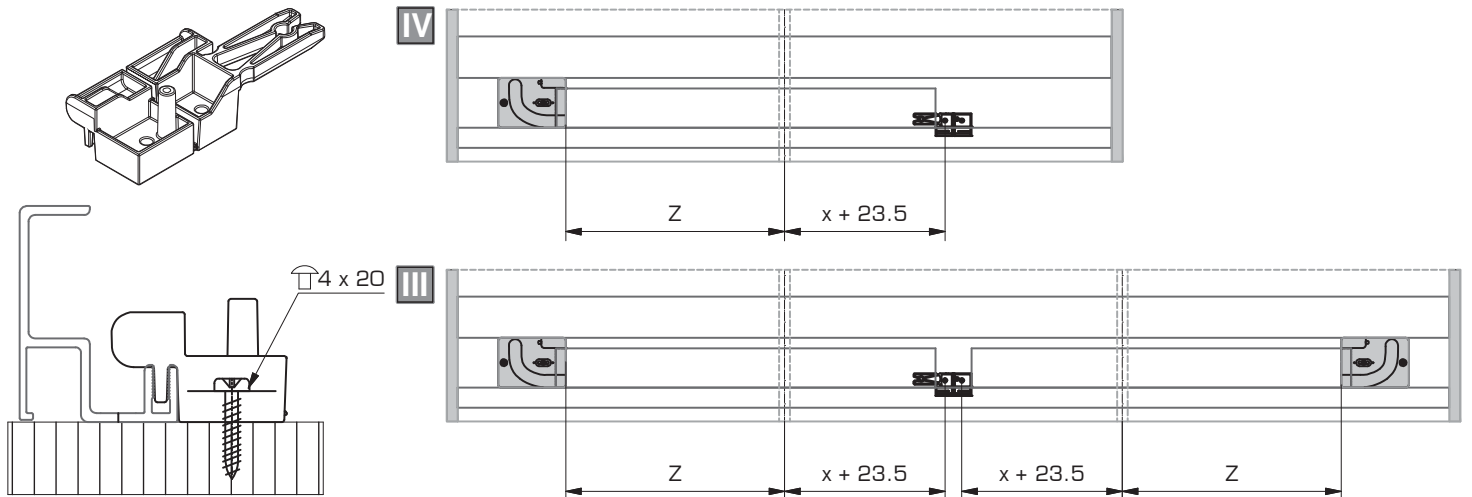



**G**

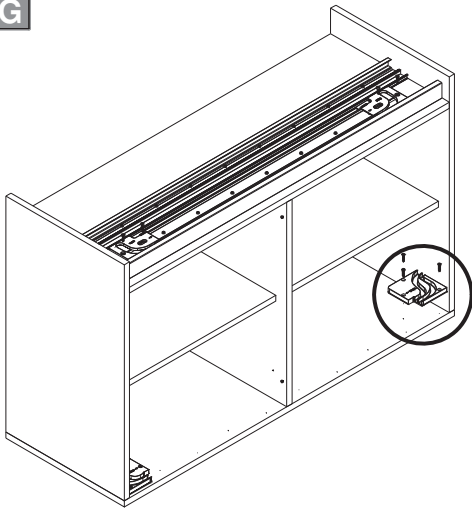

**Aufgesetzte Führung**  
Surface-mounted guide  
Guidage en applique

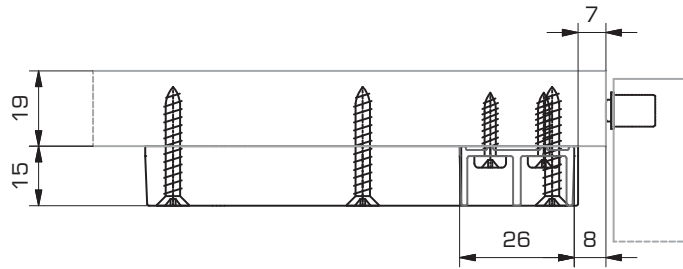
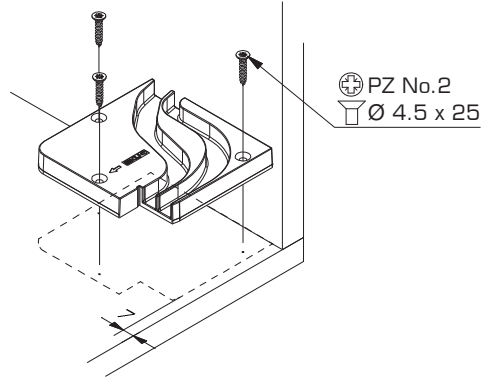

**H**

**Optionale Einbauvariante mit versenkter Führung (Kleben)**

Optional mounting example with inset guide (Glue)  
Variante de montage optionnelle avec guidage encastré (Coller)

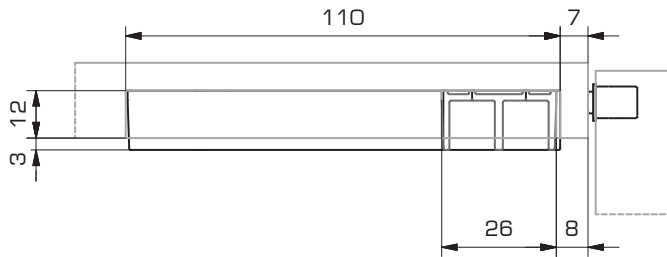
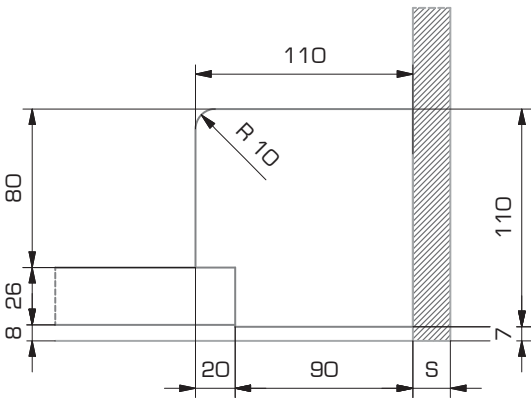

**I**

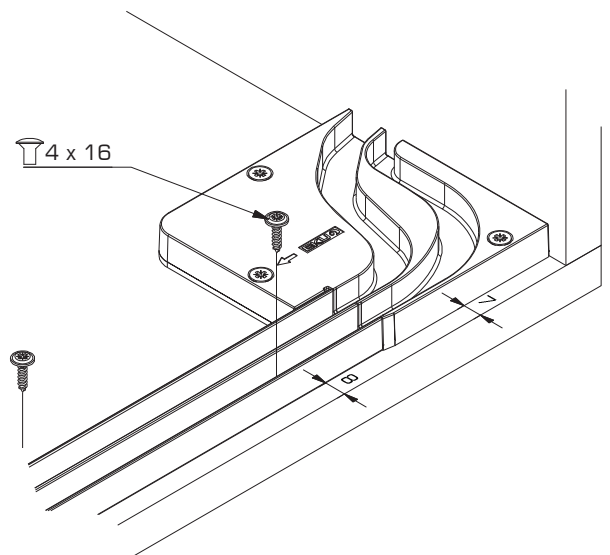
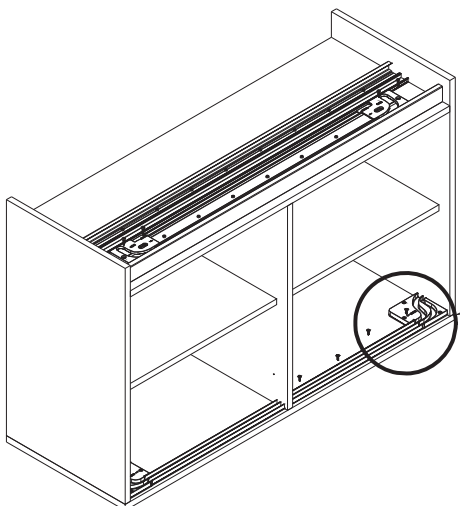

**J** Schienen reinigen!  
Clean the tracks!  
Nettoyez les rails!

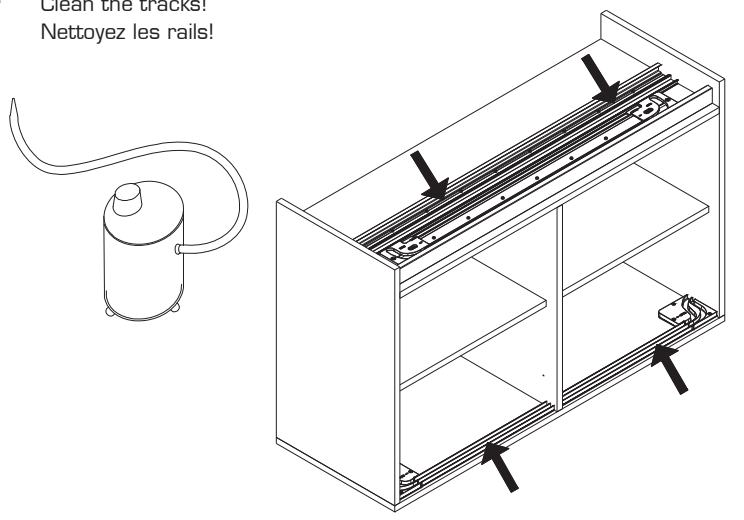

**K**

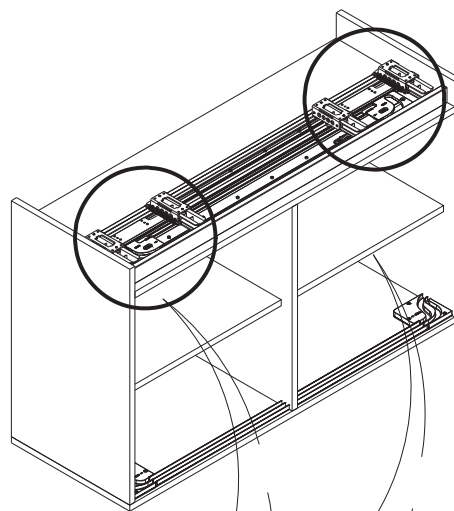

**1**

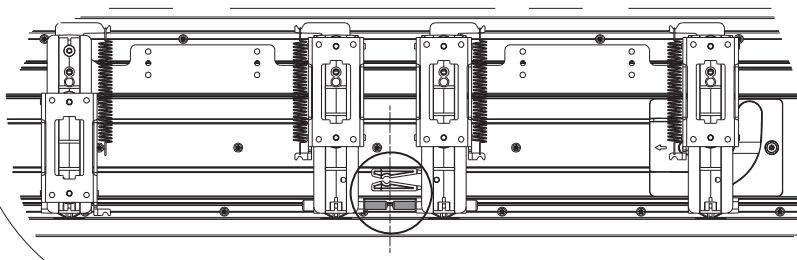
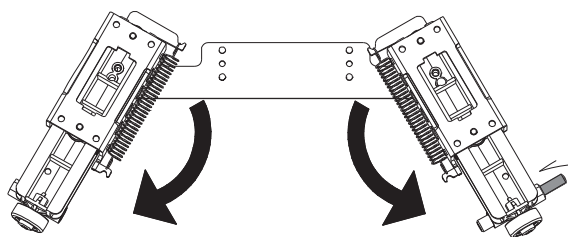

**2**

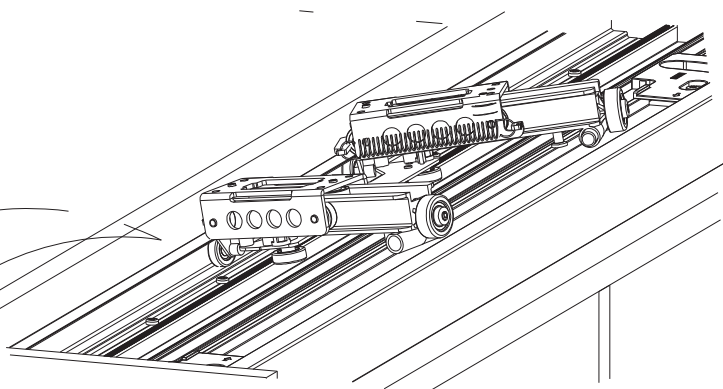
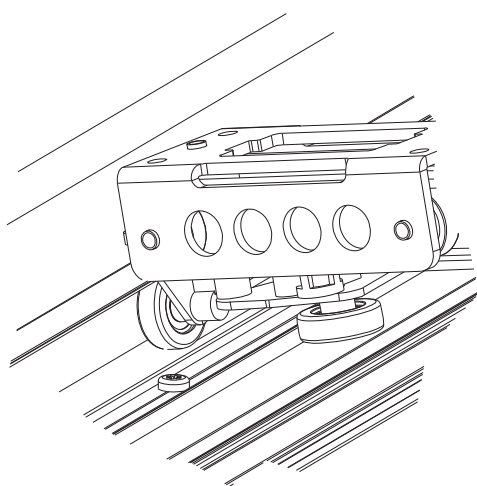

**3**

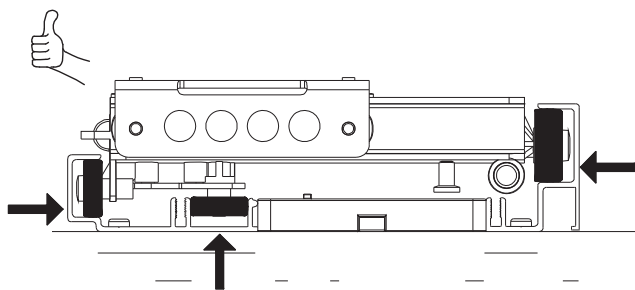
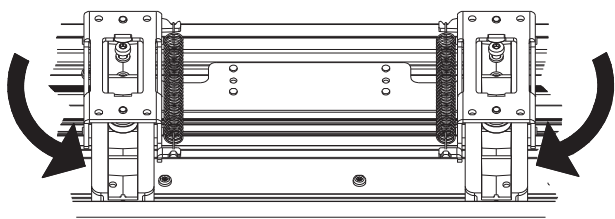

**L**

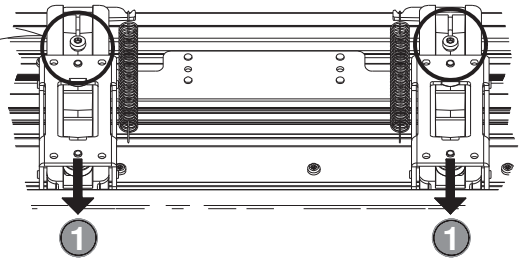
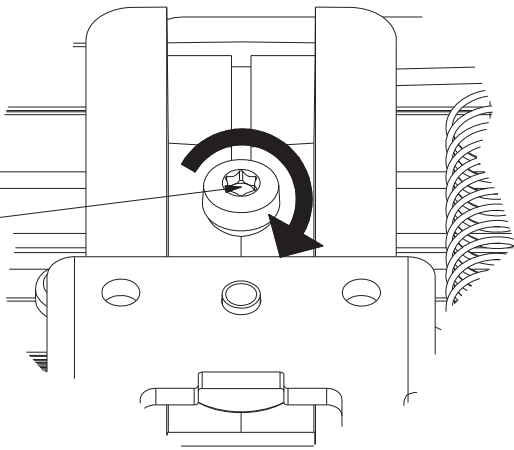
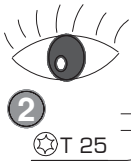

**M**

1

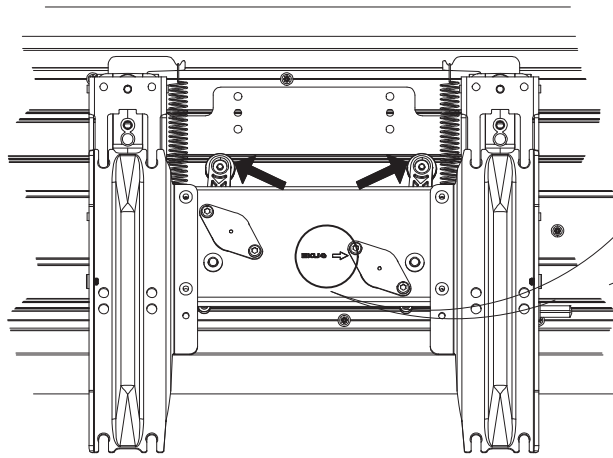
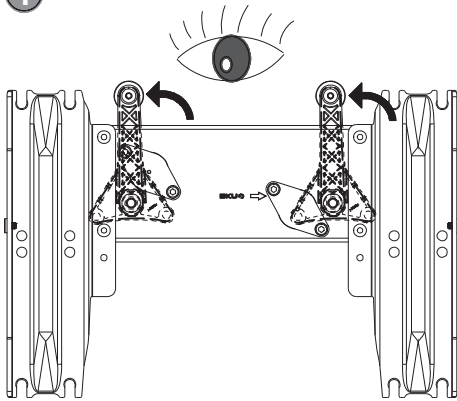

**Zeigt zur Mitte**  
Points to the center  
Montre vers le centre



2

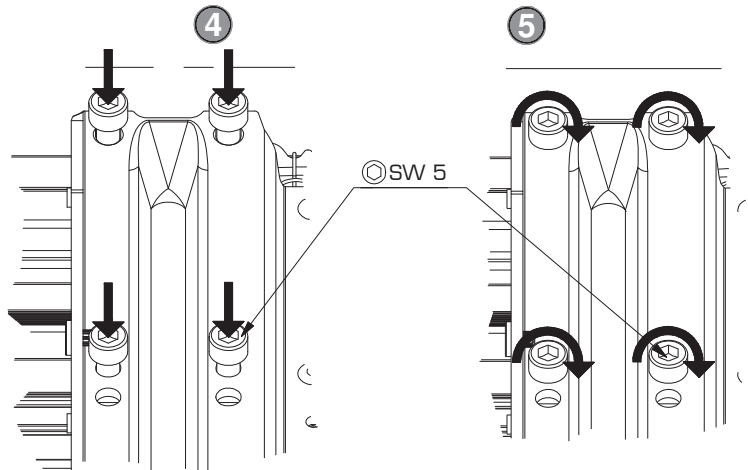
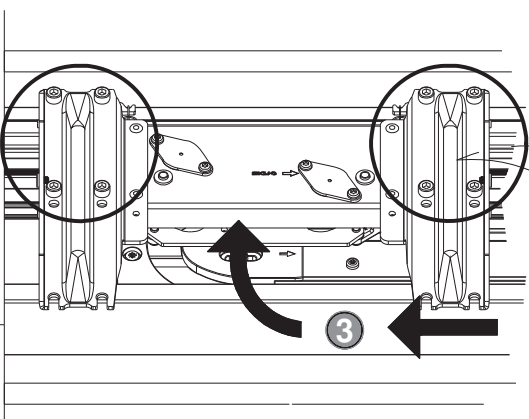
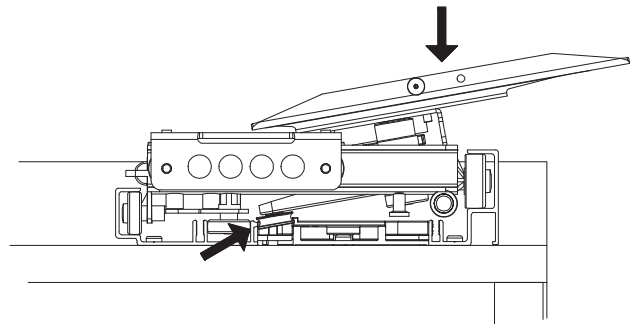
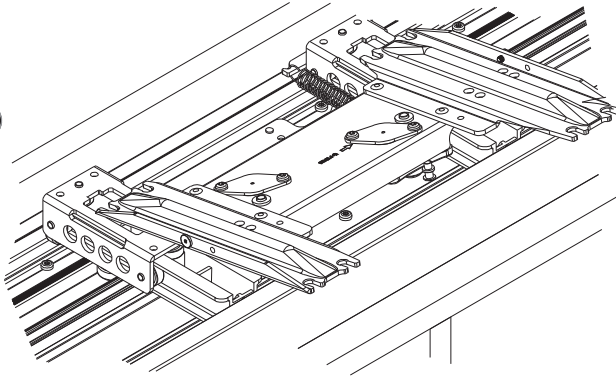

**N**

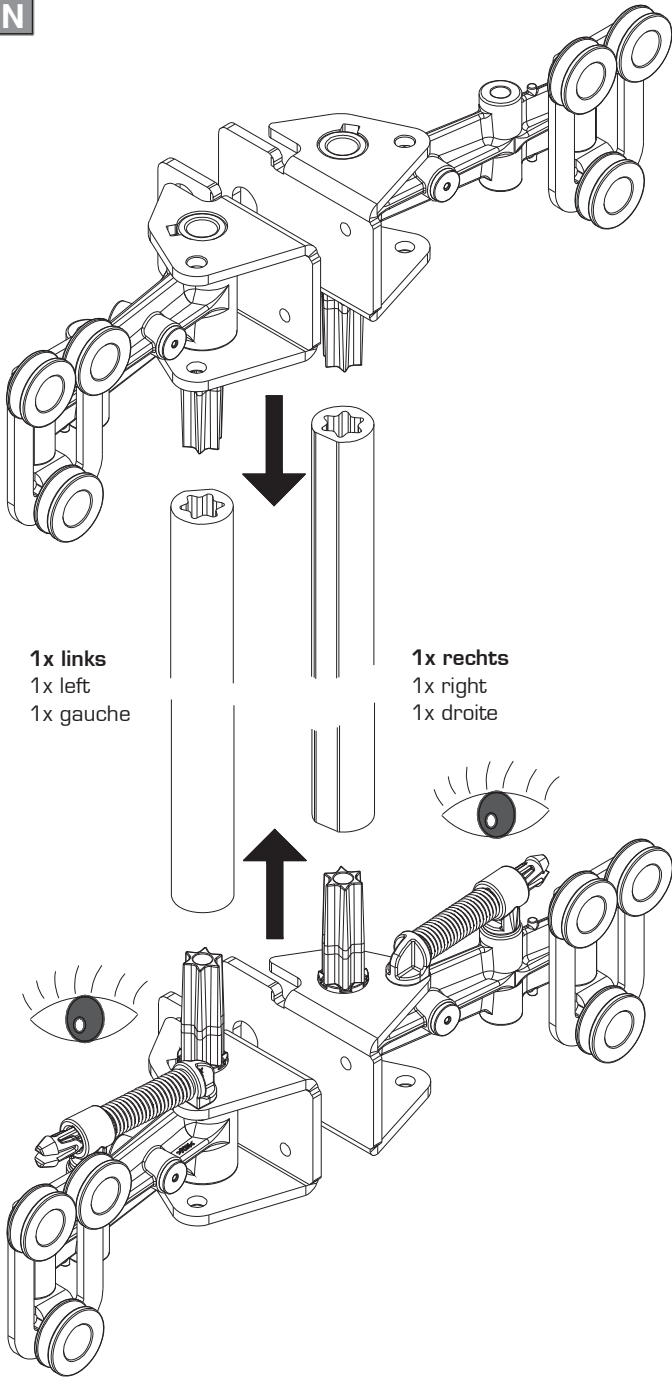

**1x links**  
1x left  
1x gauche

**1x rechts**  
1x right  
1x droite

⊕ PZ No. 2  
⊖ Ø 6.2 x 13.5

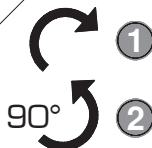

**obenlaufend | top running | à roulement en haut**

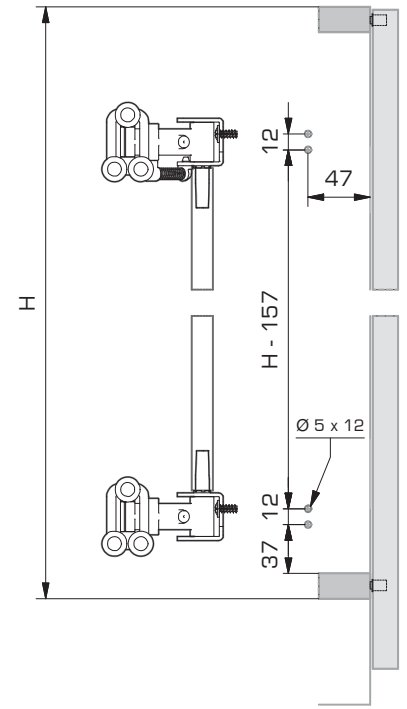
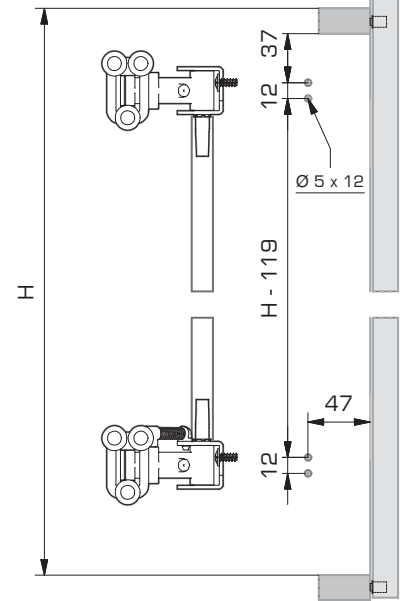

**untenlaufend | bottom running | à roulement en bas**

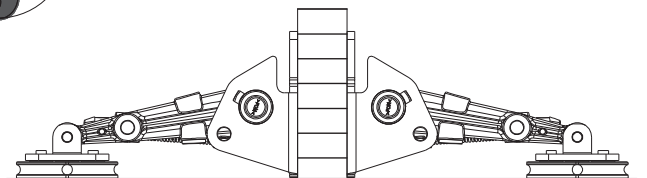

**O** Türe | Door | Porte

obenlaufend | top running | à roulement en haut

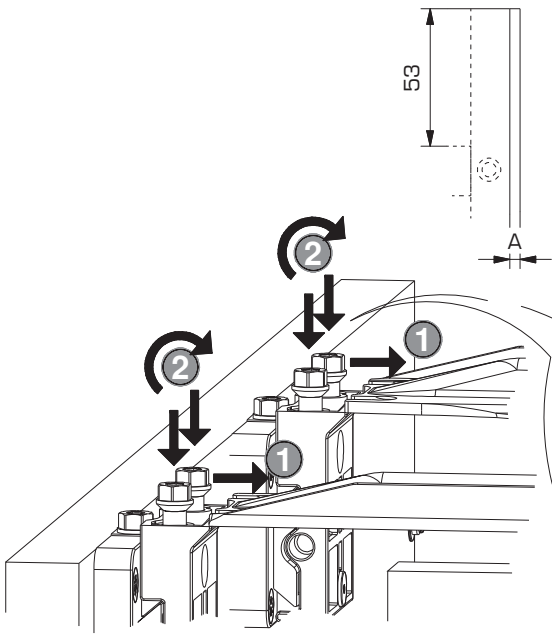

untenlaufend | bottom running | à roulement en bas

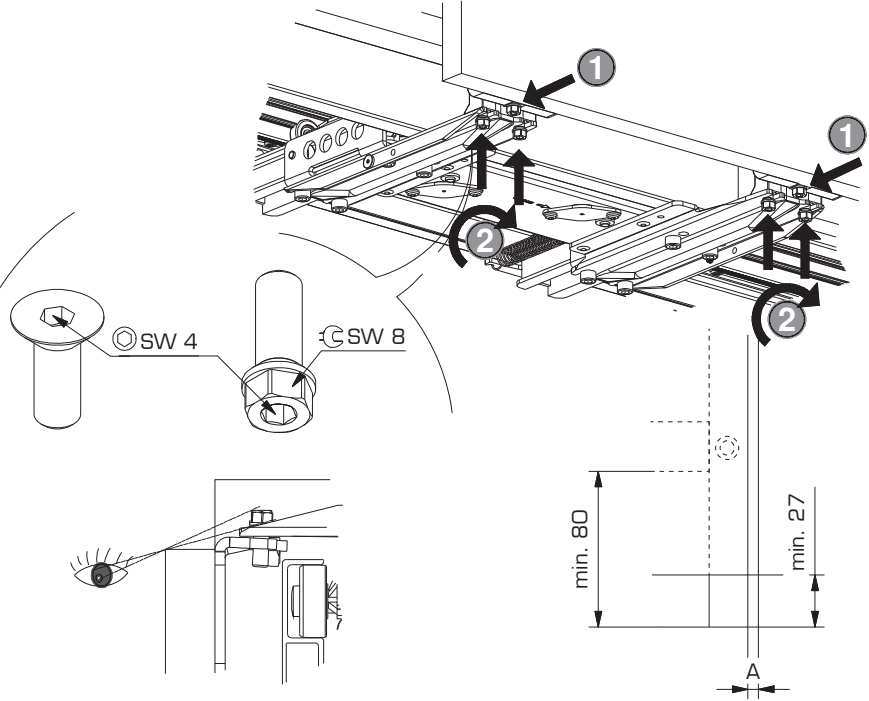

**P**

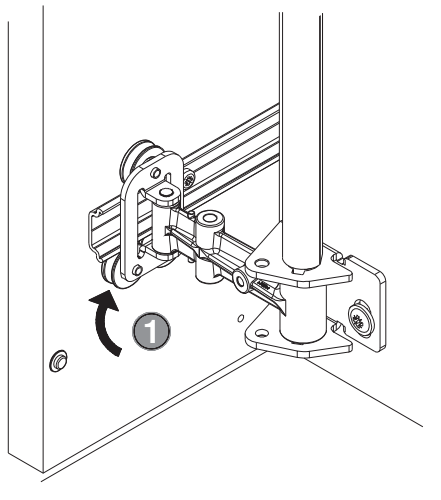

**Q** Justieren | Adjust | Ajustez

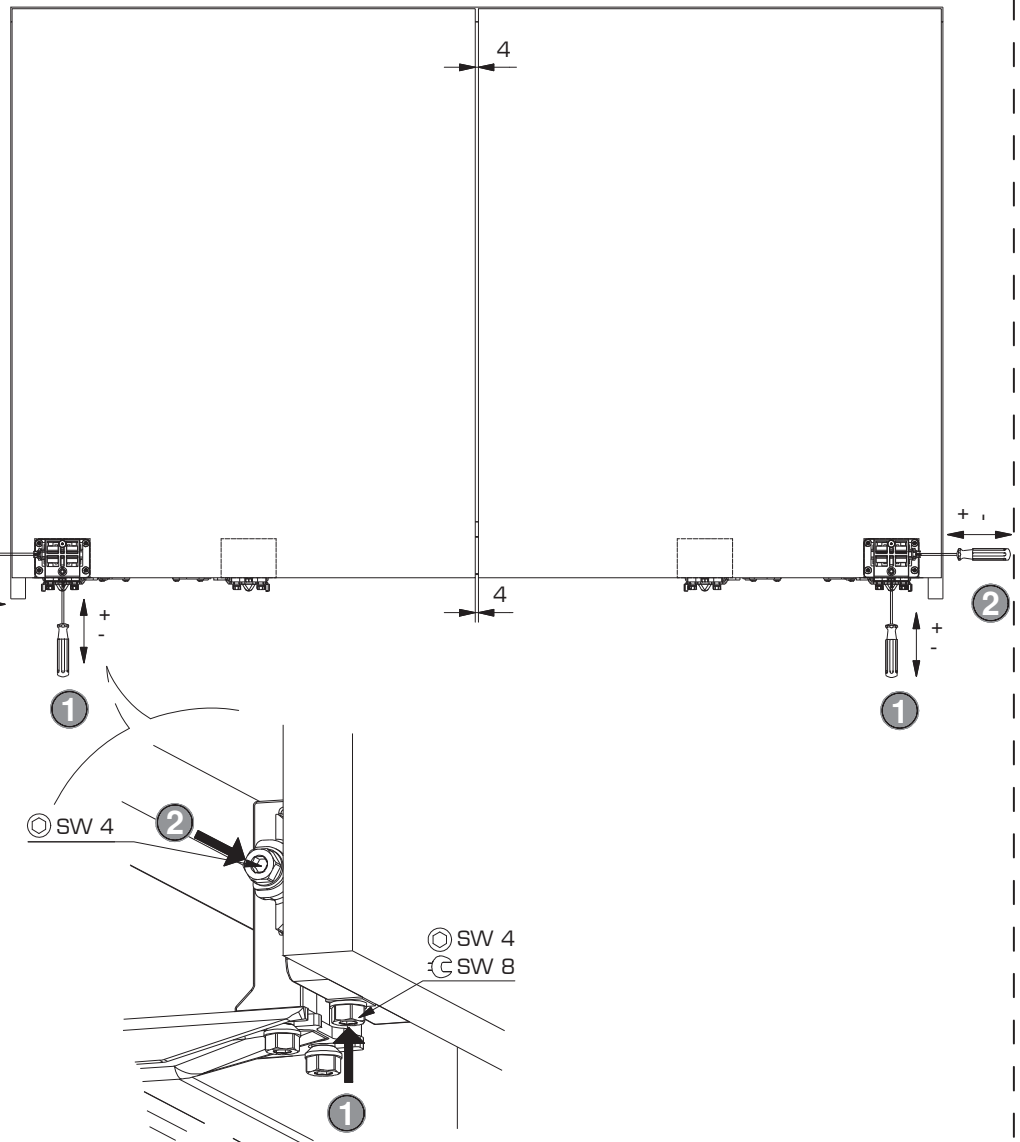

**R**

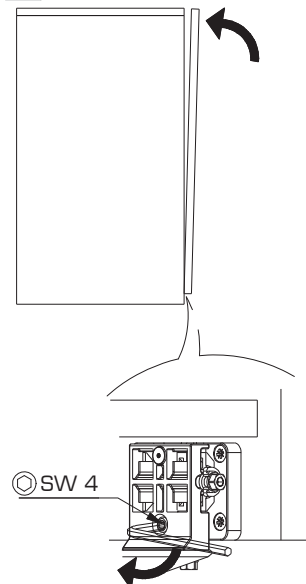

**S**

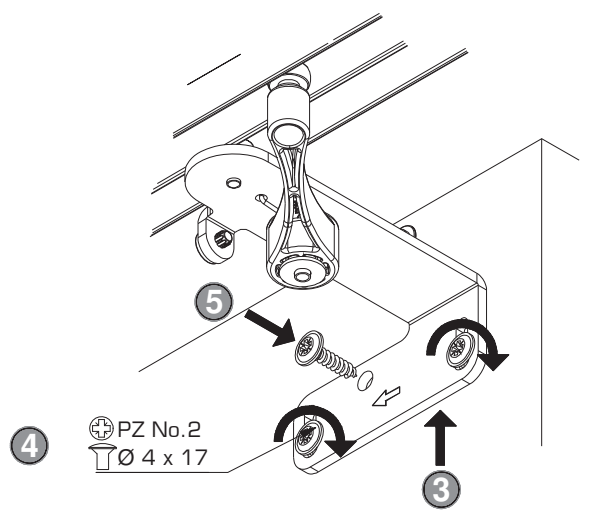
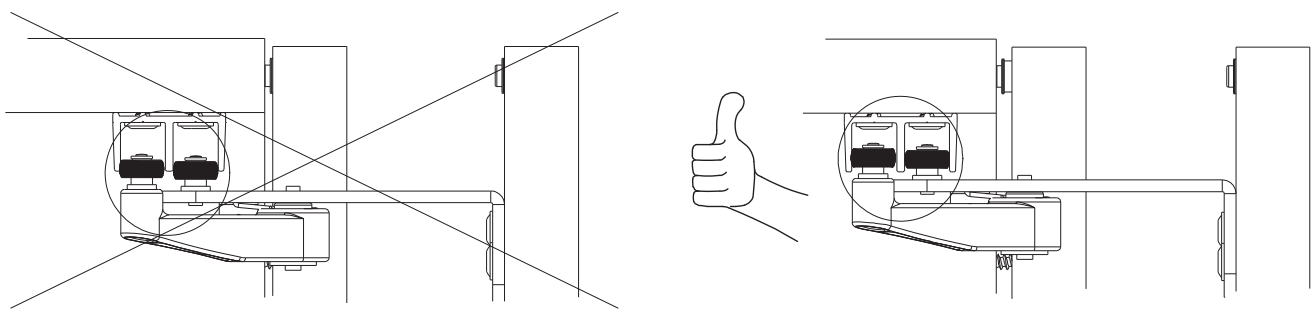
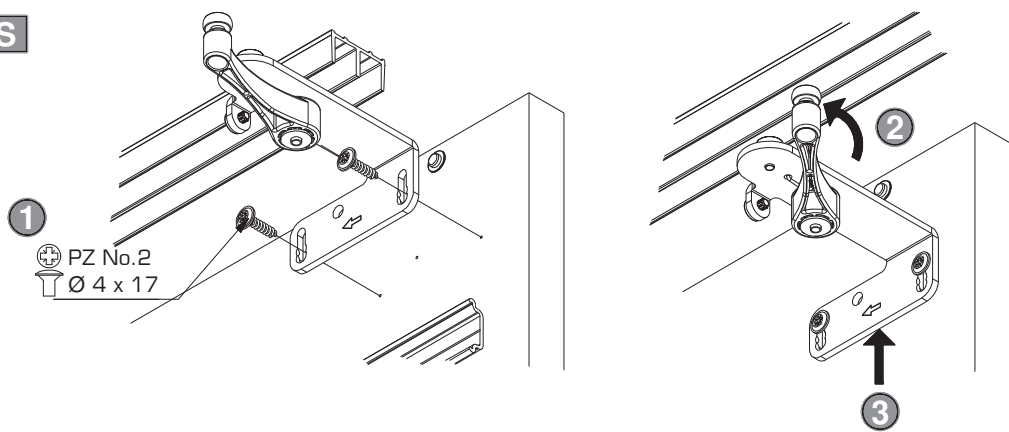

**T**

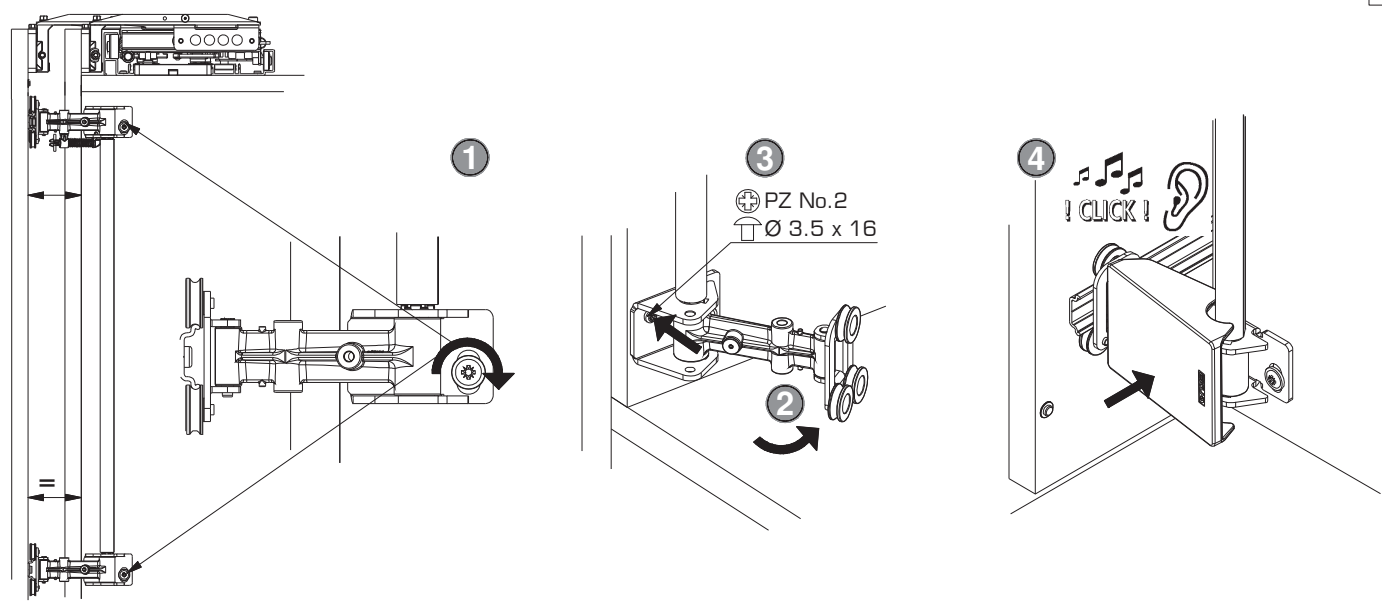

Einbaubeispiele | Mountin examples | Exemples de montage

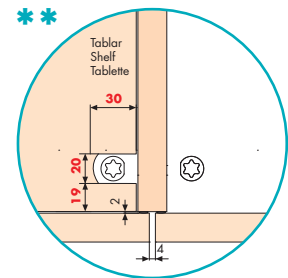
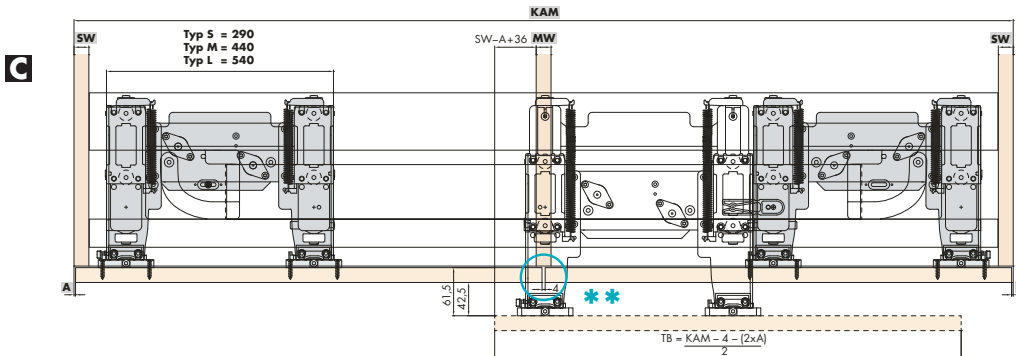
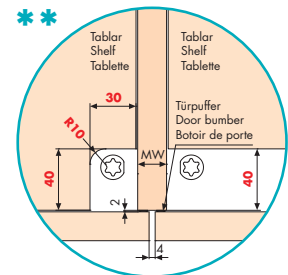
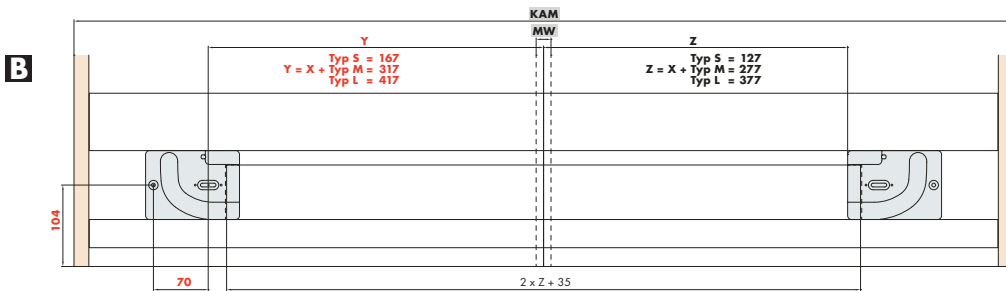
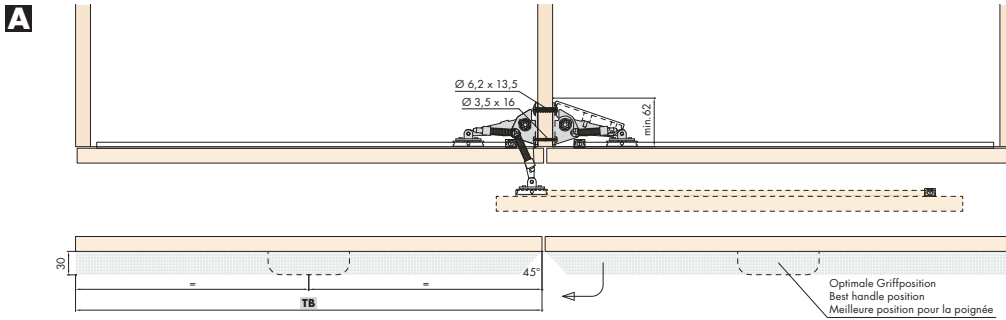
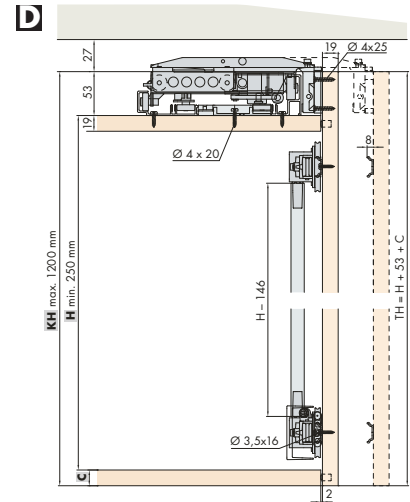
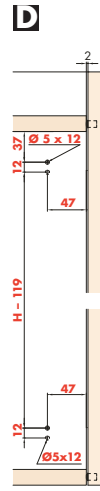
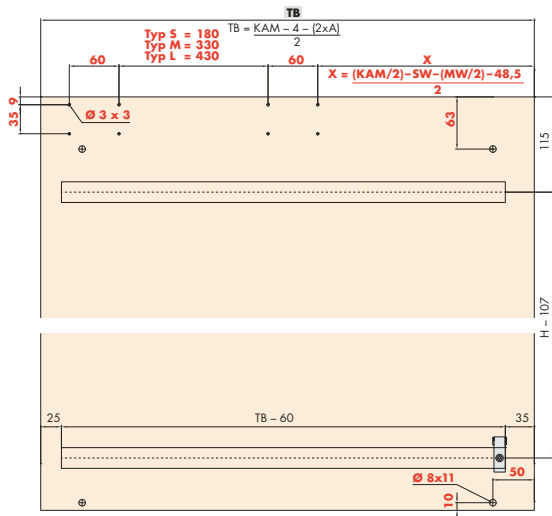



## Einbaubeispiele | Mountin examples | Exemples de montage

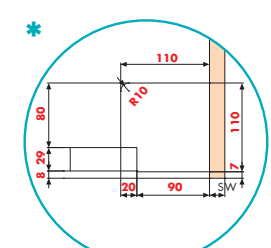
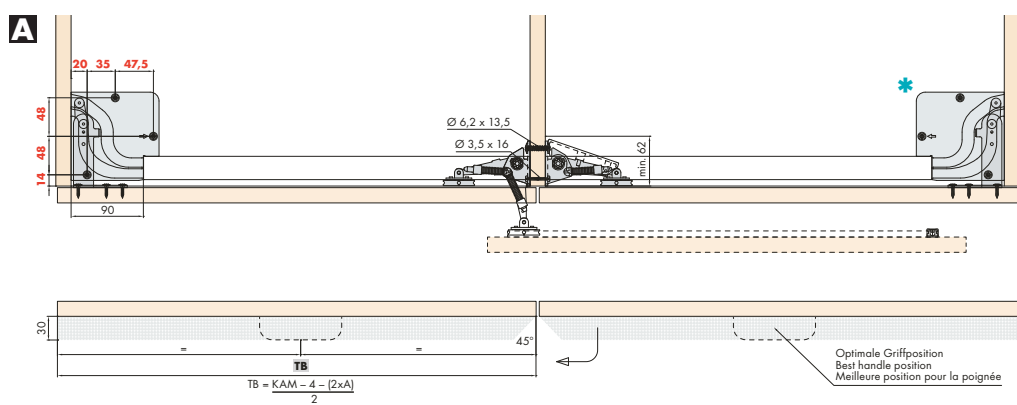
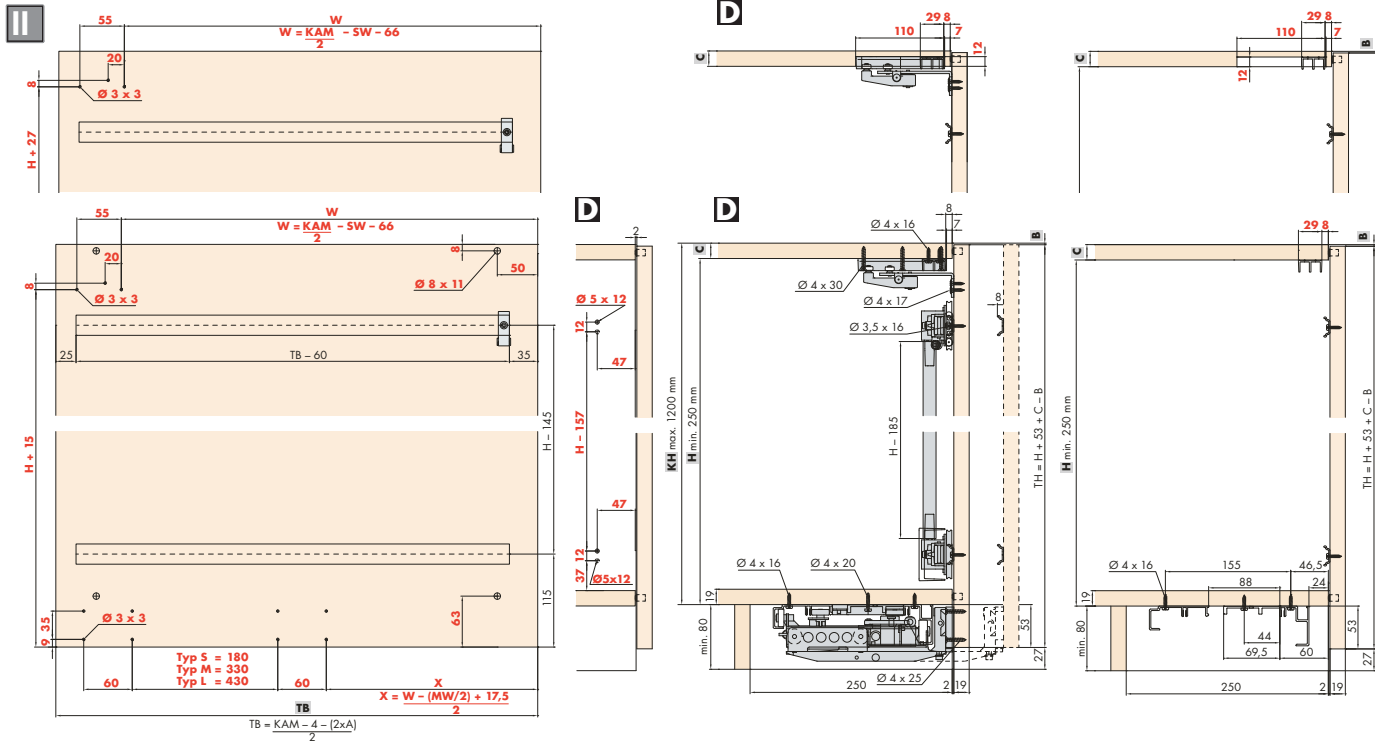

**Bearbeitung bei optionaler versenkter Führung**  
Preparation for optional inset guide  
Préparation pour guidage encastré optionelle

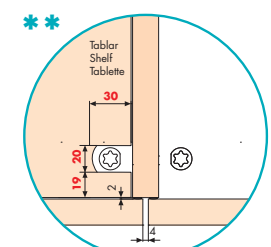
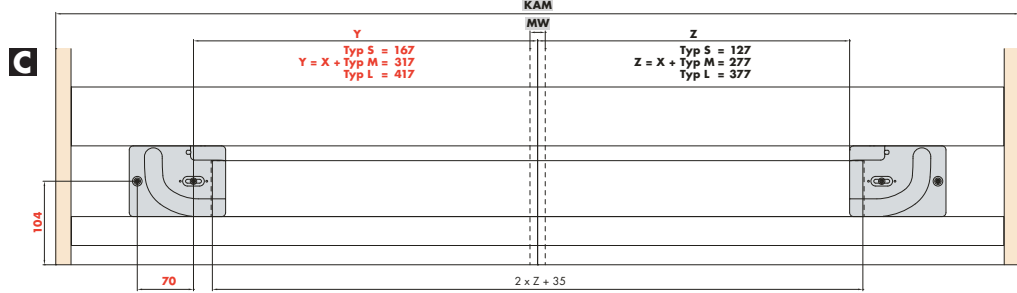
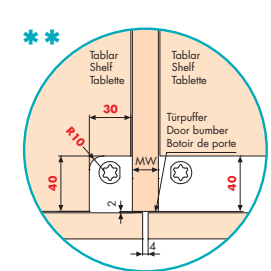
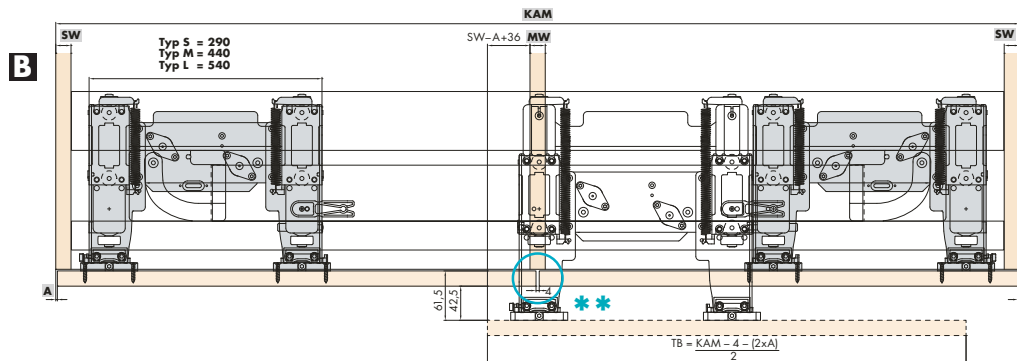

## Einbaubeispiele | Mountin examples | Exemples de montage

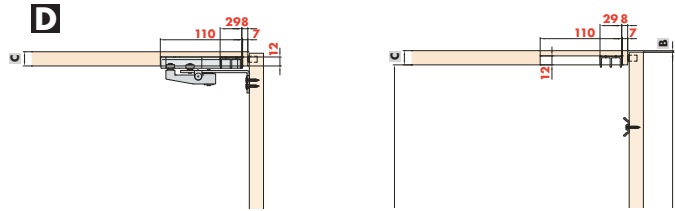
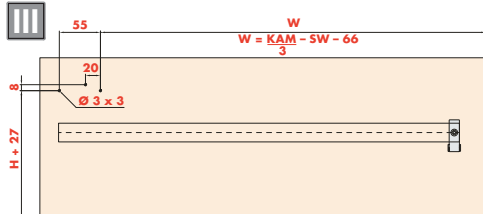

## Einbauvariante mit aufgesetzter Führung / Mounting example with surface-mounted guide / Variante de montage avec guidage en applique

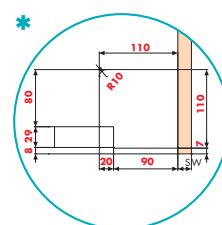
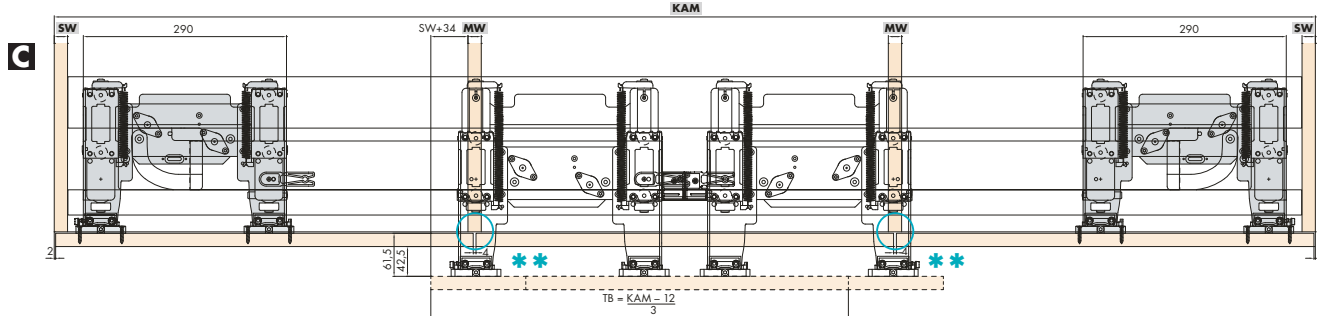
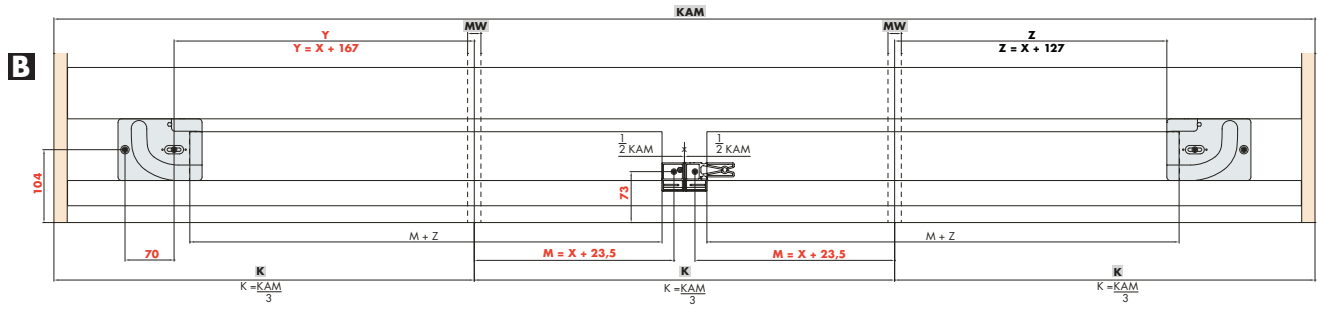
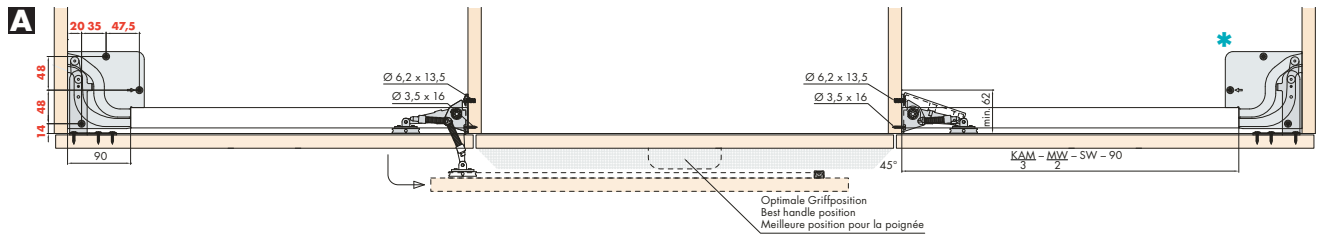
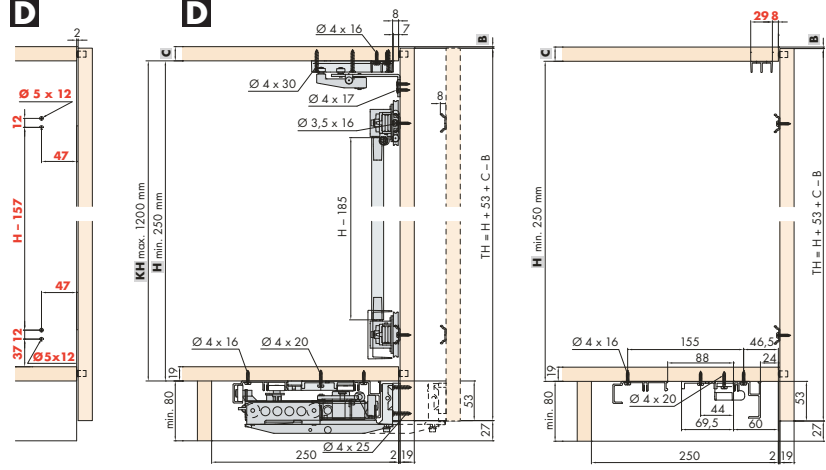
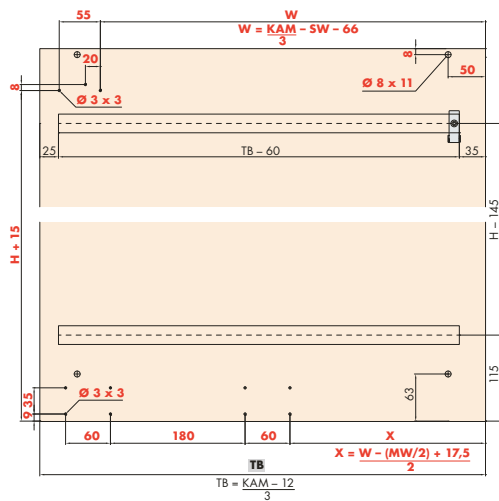

**Bearbeitung bei optionaler versenkter Führung**  
Preparation for optional inset guide  
Préparation pour guidage encastré optionelle

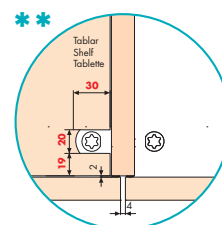
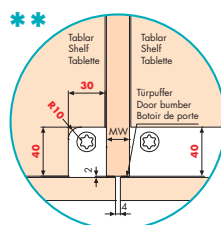

## Einbaubeispiele | Mountin examples | Exemples de montage

### IV Optionale Einbauvariante mit versenkter Führung / Optional mounting example with inset guide / Variante de montage optionnelle avec guidage encastré

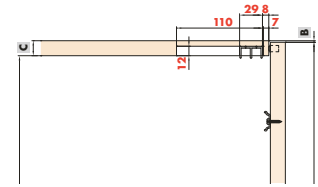
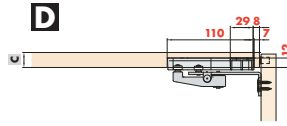
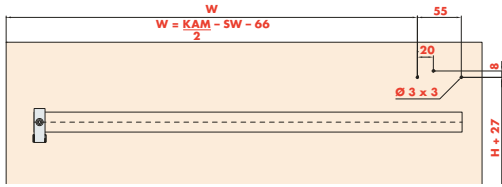

### Einbauvariante mit aufgesetzter Führung / Mounting example with surface-mounted guide / Variante de montage avec guidage en applique

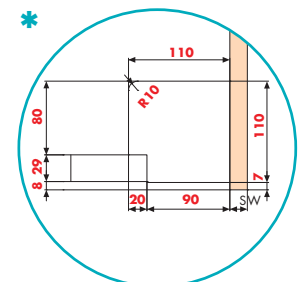
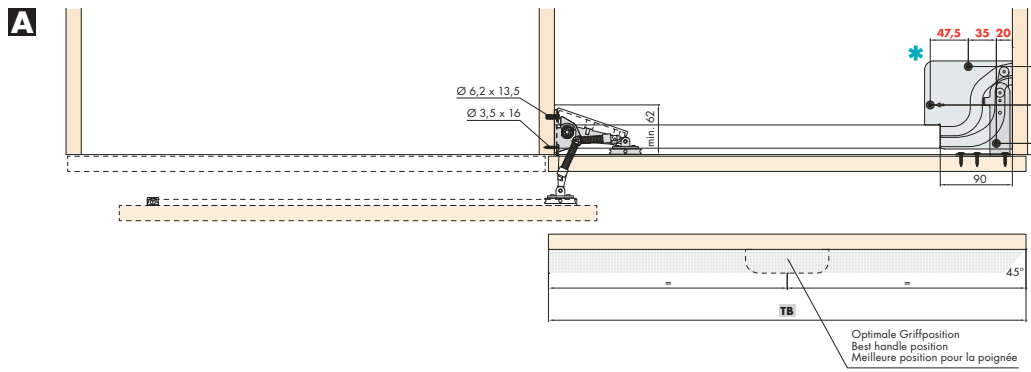
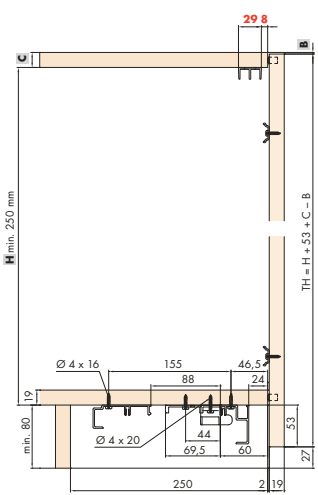
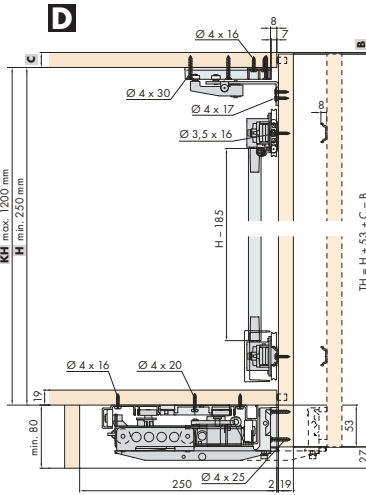
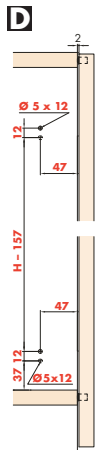
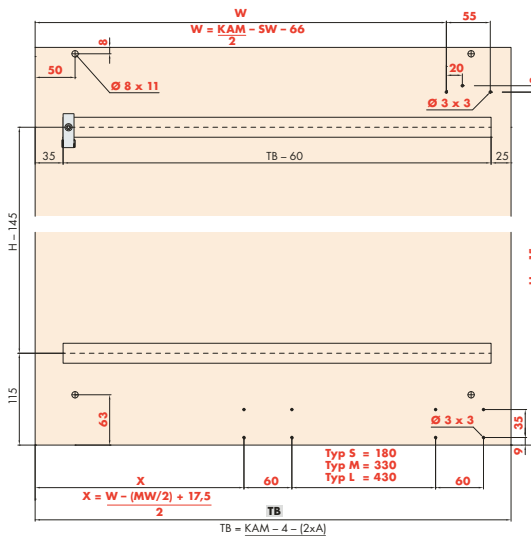

**Bearbeitung bei optionaler versenkter Führung**  
Preparation for optional inset guide  
Préparation pour guidage encastré optionnelle

