

Installation and Maintenance Guide

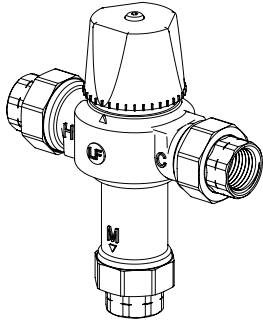

S59-4200T1

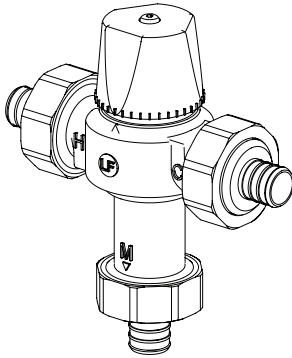

S59-4200X3

S59-4200 Series

Navigator® Thermostatic Mixing Valves

S59-4200T1 1/2" NPT Connections

S59-4200T3 3/4" NPT Connections

S59-4200S1 1/2" Sweat Connections

S59-4200S3 3/4" Sweat Connections

S59-4200X1 1/2" PEX Connections (PEX B)

S59-4200X3 3/4" PEX Connections (PEX B)

S59-4200E1 1/2" Expansion PEX Connections (PEX A)

S59-4200E3 3/4" Expansion PEX Connections (PEX A)

S59-4200P1 1/2" CPVC Connections

S59-4200P3 3/4" CPVC Connections

S59-4200Q1 1/2" Quick Connections

S59-4200Q3 3/4" Quick Connections



1017
1069
1070



Read the instructions in this manual before beginning installation. Save these instructions and refer to them for inspection, maintenance, and troubleshooting information.

For questions regarding the operation, installation, or maintenance of this product, visit bradleycorp.com or call 800.BRADLEY (800.272.3539).

Product warranties and parts information may also be found under "Resources" on our website at bradleycorp.com/customer-service/warranty.



Table of Contents

Product Performance & Specifications	2
Safety Information	3
Supplies Required	3
Tools Required.....	3
Connect Supply Lines	4
Adjust Water Temperature.....	6
Test Unit.....	6
Troubleshooting: Thermostatic Mixing Valve	7

Product Performance & Specifications

Inlet Connections: 1/2" or 3/4" NPT, Sweat, PEX A & B, CPVC or Quick Connect

Outlet Connection: 1/2" or 3/4" NPT, Sweat, PEX A & B, CPVC or Quick Connect

Minimum Supply Pressure Static: 20 psi (138 kPa)

Maximum Pressure: 125 psi (860 kPa)

Minimum Flow: 0.5 gpm (1.9 Lpm) (ASSE 1070 applications)

Maximum Flow: 20 gpm (76 Lpm) @ 125 psi (862 kPa)

Maximum ASSE 1017 Flow: 3.0 gpm (11.4 Lpm) @ 10 psi (68.9 kPa) differential

Maximum Temperature: 180°F (82°C)

Minimum Temperature Differential (from value set point with equal pressure): 5°F (3°C)

Maximum Hot Water Temperature: 180°F (82°C)

Hot Water Inlet Temperature: 120–180°F (49–82°C)

Cold Water Inlet Temperature: 39–85°F (4–29°C)

Maximum Pressure Differential between Hot and Cold Water Supplies: 25%

Temperature Range: 80–120°F (27–49°C), adjustable.



For use with showerheads rated at 1.5 gpm (5.7 Lpm) or higher (ASSE 1069 applications).

Safety Information

To ensure proper operation:

Installation

When used in an ASSE 1017 application at the hot water source, the Bradley Thermostatic Mixing Valve S59-4200 Series cannot be used by itself to control final temperature at fixtures where ASSE Standard 1016 or ASSE Standard 1070 listed devices are required. Such use may result in severe bodily injury (i.e. scalding or chilling) and/or death. ASSE Standard 1016, ASSE 1069 or ASSE Standard 1070 listed devices should be used at point-of-use to prevent possible injury.

Recirculation systems should recirculate water at temperatures over 140°F to reduce the risk of bacterial growth in the piping.

This valve should not be used at the hot water source in recirculation systems.

This valve does not provide protection from pipe freezing.

Installation of this system must be completed by a qualified plumber in compliance with all national and local codes.

Compliance and conformity to local codes and ordinances is the responsibility of the installer. Should these codes differ from the information in the manual, follow the local codes. Inquire with governing authorities for additional local requirements.

Inspection

Regular checking and cleaning of the valve's internal components and check valves along with plumbing connections is necessary for maximum life and proper product function. **Periodic inspection and yearly maintenance by a licensed contractor is required.** Corrosive water conditions and/or unauthorized adjustments or repairs could render the valve ineffective for its intended service. Frequency of cleaning and inspection depends upon local water conditions.

Output temperature of each valve section must be individually checked and adjusted at initial installation and on a quarterly basis.

Water Temperature

Final temperature adjustment is the responsibility of the installer. Refer to the Product Performance & Specifications section on page 2 for maximum temperature information.

Supplies Required

- Shut-off on the outlet if tempered water is supplied to a remote location
- Shut-off on the inlets/supplies

Tools Required

- Adjustable wrench
- 3/32" Hex wrench
- Appropriate tools for connection type ordered

1 Connect Supply Lines

⚠ WARNING Make sure that all water supply lines have been flushed and then completely turned off before beginning installation. Debris in supply lines can cause valves to malfunction.

✓ Close the nearest upstream hot and cold water shut-off valves, and bleed the remaining water from the system prior to starting this procedure.

A Connect the water supply to the valve, depending on the application shown in the illustrations below.

B Locate a place for the tempering valve that is easily accessible for service and adjustment and is as close to the point-of-use as possible.

IMPORTANT: For valves with quick-connect tailpieces, refer to the Quick-Connect Installation section AND then skip to Step E of this procedure.

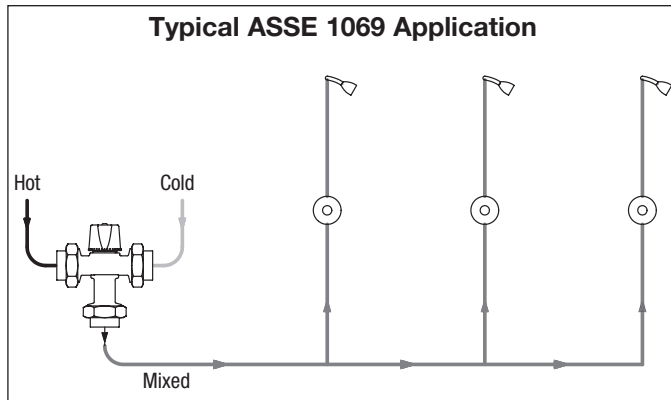
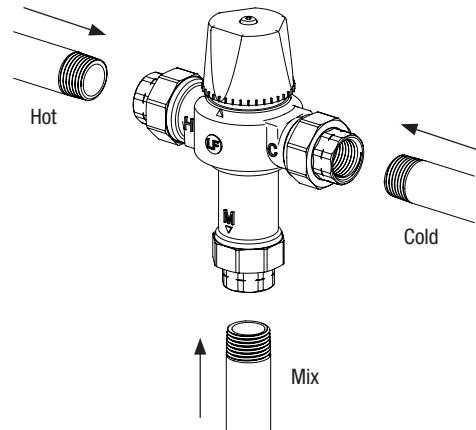

✓ It is recommended that the shutoff valve(s) be installed on the inlet(s) to facilitate service on a 4200 Series valve.

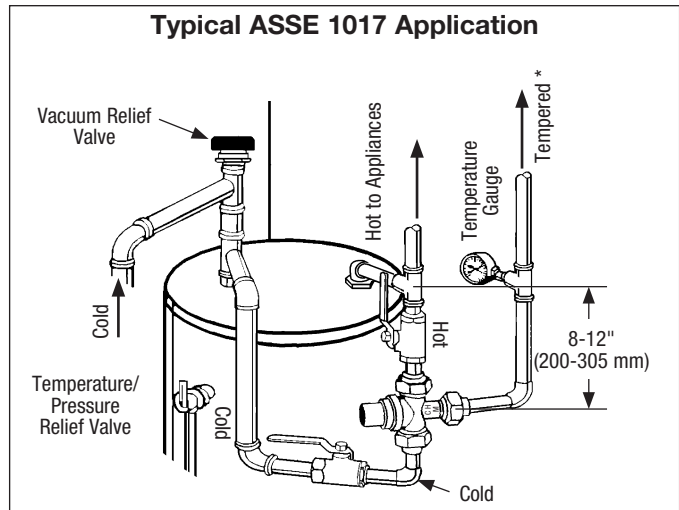
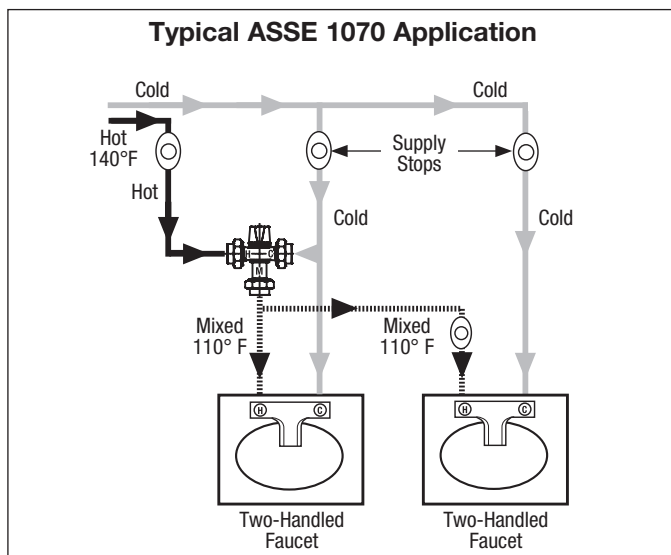

✓ To prolong the life of a 4200 Series valve when used in an ASSE 1017 application, it is recommended that it be trapped as shown above. Note the hot water inlet should be 8-12" (200-305 mm) below the hot water supply feed.

C Connect the inlet hot supply to the H side of the valve, the cold supply to the C side, and the mixed water outlet to the M side.

D Install the union nuts over the tailpieces. Do this prior to soldering, threading to the pipe or using with a press.

✓ DO NOT overtighten unions.

✓ *DO NOT solder with inlet and outlet tubes attached to the valve. Excessive heat will damage the rubber and plastic components of the valve.*

E When soldering is complete, flush the piping and then install the valve using the filter washer on the hot and cold water inlet and the fiber washer on the mixed water outlet.

F Turn on hot and cold water supplies. Check for leaks. Tighten connections as necessary to stop leaks before proceeding.

Quick-Connect Installation

To Connect

A Mark the pipe insertion depth on the pipe.

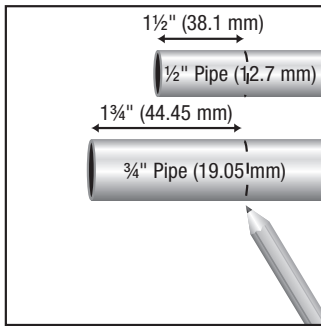

B Clean off the pipe end using a fine emery cloth.

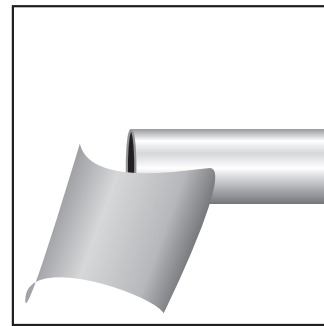

C If using PEX tubing, insert the pipe stiffener (provided) into the end of the pipe.

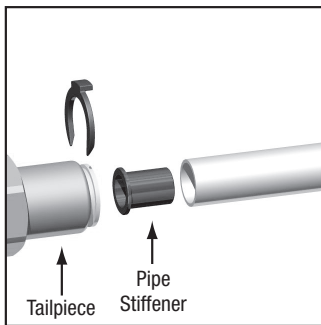

D Push the tubing into the tailpiece up to the mark, and then insert the collet clip.

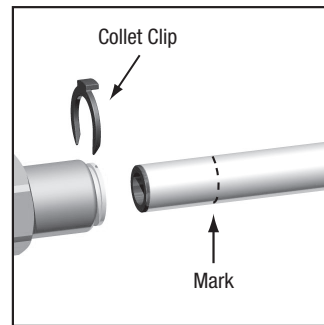

To Disconnect

A Remove the collet clip.

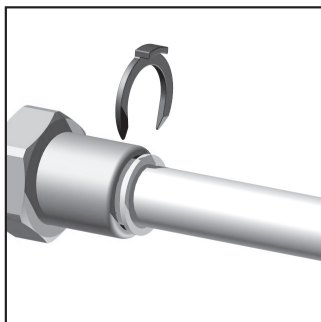

B Depress the collet, and then pull the tubing from the tailpiece.

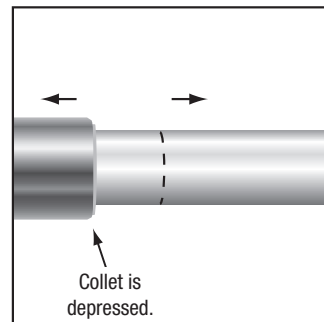

2 Adjust Water Temperature



Water temperatures in excess 110°F (43°C) are dangerous and may cause scalding, severe injury or death! This valve can be adjusted to deliver water at temperatures exceeding 110°F (43°C). Consequently, when used in an ASSE 1016, ASSE 1069, or ASSE 1070 application, the installer must check the mixed water outlet temperature at the point of use and adjust the thermostatic mixing valve to ensure delivery of water at a safe temperature not exceeding 110°F (43°C).

Mechanical valves are not fail-safe. Due to the effects of various water conditions, periodic verification of outlet water temperature is required.



This valve is factory preset to 105°F (41°C). Upon installation, the temperature of this valve must be checked and adjusted to ensure delivery of a safe water temperature.

A Let the water flow for at least two minutes to allow the supply temperature to stabilize.

B Place a thermometer in the mixed water stream to calibrate the mixed water outlet temperature.

Adjust the valve setting.

- C**
- Use the hex wrench to loosen the cap screw. The cap screw must be lifted ¼" to adjust the temperature.
 - To **increase** temperature, turn cap **counterclockwise**. To **decrease** temperature, turn cap **clockwise**.

D Lower the cap and tighten the cap screw.

E Recheck the mixed water outlet temperature.

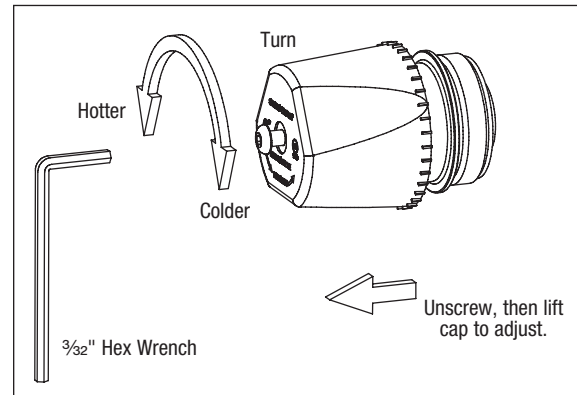

3 Test Unit



DO NOT SKIP THIS STEP!!!

Shut the hot water inlet off by closing hot water inlet valve. While the hot water supply is turned off, check to make sure the cold water flow is reduced. If the cold water is reduced properly, reopen the hot water supply.

Shut the cold water inlet off by closing the cold water inlet valve. While the cold water supply is off, check to make sure that the hot water flow has shut down.

Troubleshooting: Thermostatic Mixing Valve



Before attempting to troubleshoot the valve or disassemble the components, check for the following conditions:

- If stop valves are used, make sure that they are fully open.
- Make sure that the hot and cold inlet pipes are connected properly, and that there are no cross-connections or leaking stop valves.
- Check the hot water heater output to make sure that it is at least 5°F (3°C) above the set temperature.



Be sure to close the appropriate shut-off valves prior to disassembly of the valve and reopen the valves after inspection and repair is complete.

Problem	Cause	Solution
Unable to reach required set point or set point is difficult to set up.	Supply temperatures not within specified limits.	Check differential temperature between hot and cold supplies and outlet 5°F (3°C) minimum required.
	Hot and cold supplies are reversed.	Reinstall valve with supplies connected to marked inlets.
	Filters are blocked by debris.	Clean the filters.
Unable to achieve required flow.	Too much pressure drop at fixture.	Measure supply pressures and check against flow chart. Look for restrictions in valve or piping.
	Checks valve/filters blocked by debris.	Clean check valves/filters.
Valve does not maintain required temperature or temperature changes over time.	Fluctuation in supply pressures.	Stabilize water pressures using pressure regulating or balancing valves.
	Check valve/filters blocked by debris.	Clean check valves/filters.
	Recirculation loop not piped properly.	Pipe recirculated tempered water return so it connects to hot water source and cold side of Tempering valve (see Product Guide for piping details).
Discharge temperature too hot or too cold.	Valve not calibrated properly.	Readjust valve temperature per installation instructions.
Hot water from cold water tap or cold from hot.	Check valves fouled.	Clean check valves/filters.
Valve is noisy.	Water velocity is too high.	Reduce water velocity with pressure regulating valves.
	Valve not sized properly.	Check flow required versus rated flow capacity of valve.
No flow from valve.	Hot or cold water supply failure or shutoffs are closed.	Open shutoffs or restore hot and cold supply.
	Check valve/filters blocked by debris.	Clean check valves and filters.
Flow from valve fluctuates.	Fluctuation in supply pressures.	Stabilize water pressure with pressure regulating valves.
	Check valve/filters blocked by debris.	Clean check valves and filters.