

Installation

WashBar™ Soap Bracket Upgrade Kit

S65-512

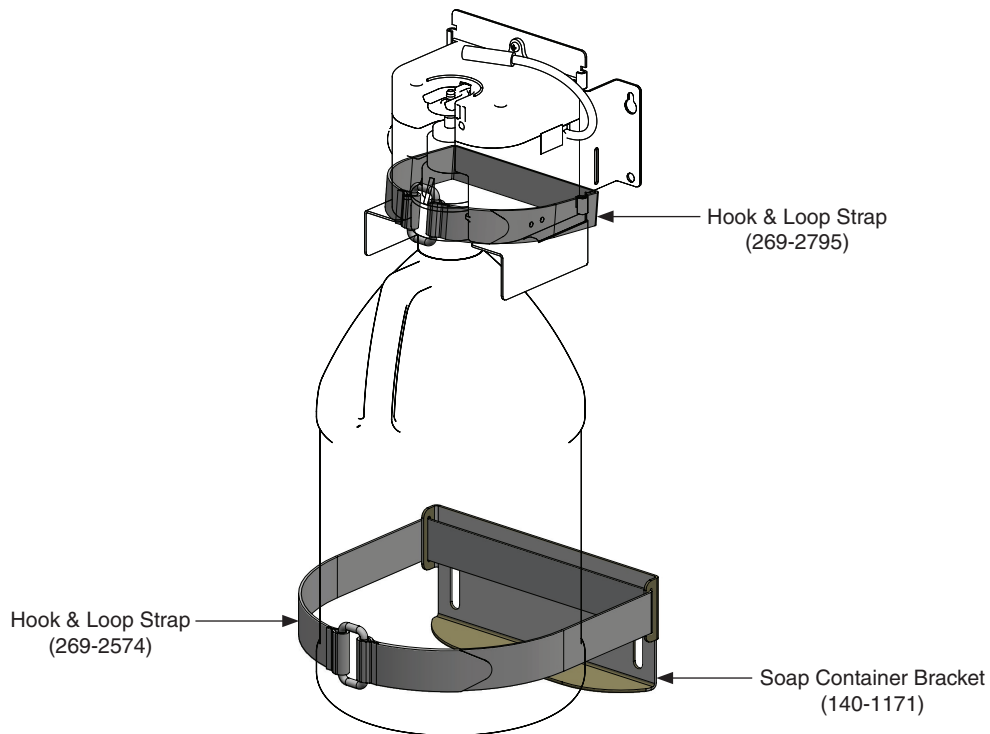

Read the instructions in this manual before beginning installation. Save these instructions and refer to them for inspection, maintenance, and troubleshooting information.

For questions regarding the operation, installation or maintenance of this product, visit bradleycorp.com or call 800.BRADLEY (800.272.3539). Product warranties and parts information may also be found under "Resources" on our website at bradleycorp.com.



1 Remove Soap Container

A Remove the gallon soap container and set aside.

2 Attach Hook and Loop Strap (269-2795)



The upgrade kit contains a hook and loop strap (269-2795) to secure the soap motor in place.

A Attach and tighten the hook and loop strap (269-2795). Refer to the figures below to determine the placement of the hook and loop strap.

Soap Motor Bracket with Slot

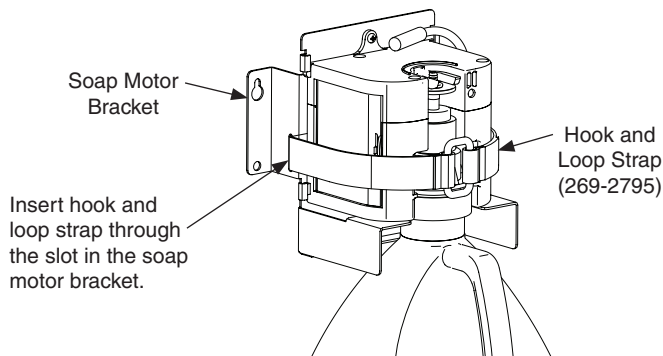

Soap Motor Bracket without Slot

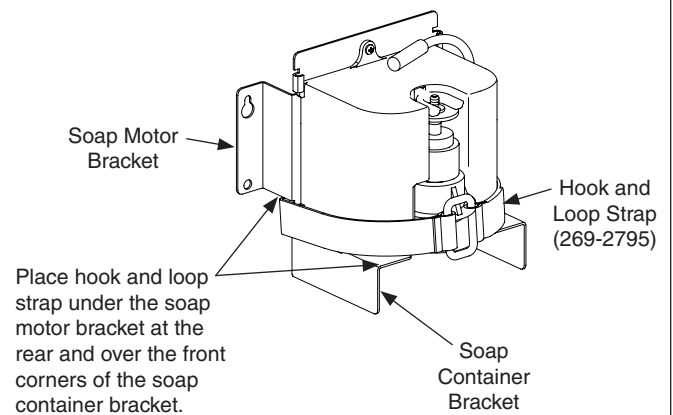

B Ensure that the soap tube is not kinked. Position hand above soap motor control box and adjust tube if needed.

3 Replace Soap Container Bracket (240-1171)

A Remove the hook and loop strap and the existing soap container bracket from the wall by loosening and removing the #10 screws.

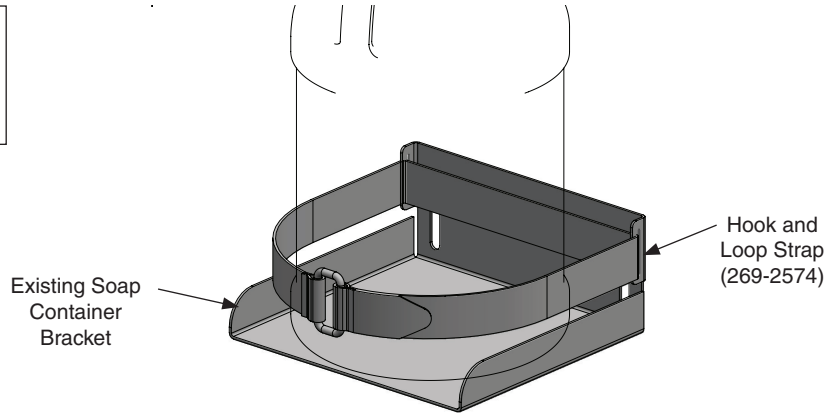

B Use the existing mounting holes to attach the new soap container bracket to the wall with the #10 screws previously removed.

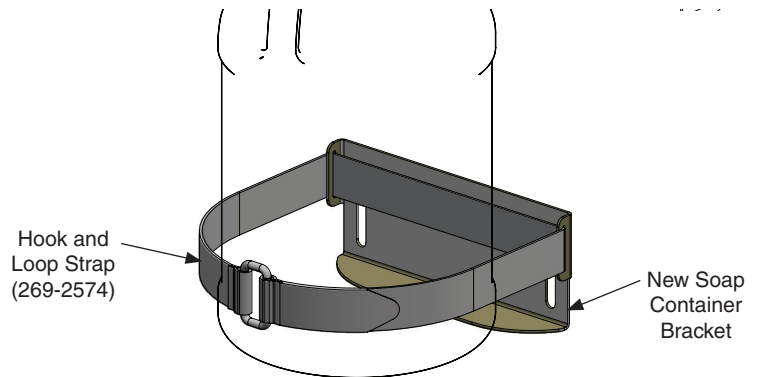

C Slide soap container over soap syphon tube and into soap pump. Adjust soap container bracket as necessary. Tighten the #10 screws to secure the bracket in place.

The liquid soap pump has a rubber sleeve that fits over the soap container opening. The foam soap pump has an interior white cylinder that fits into the soap container. The fit may be tight. Move the soap pump laterally while applying pressure to seat into the soap container opening.

D Use the provided hook and loop strap (269-2574) to secure container to soap container bracket. Feed end (smooth side facing you) through the right side slot of bracket flange at top. Feed through left side flange slot and wrap around jug. Secure with the hook and loop end.

E To manually prime the soap, press down on the control box lever arm 6 to 8 times.

